

1 Scope:

- 1.1 This specification is applicable to fully lead-free and halogen-free FSA series reverse flat type thick film chip resistors array.
- 1.2 Fully lead-free products without RoHS exemptions
- 1.3 The product is for general electronic purpose.
- 1.4 Superior sulfur resistant capability (Refer to ASTM-B-809-95&EIA977 sulfur vapor test).

2 Explanation Of Part Numbers:

FSA	01	- 4	V	100	J	B	TH
Type	Size (inch)	Number of Circuits	Terminal Type	Normal Resistance	Tolerance	Fos Test	Packaging(Refer to IE-SP-055)
Fully lead-free Anti-sulfurated Thick Film Chip Resistors Array	01(0201)	2: 2circuits 4: 4circuits	V :Reverse Flat Type	5% (3-Digit)	F=± 1.0% J=± 5.0%	B=105°C	TH : 2 mm Pitch Carrier Tape 10000 pcs H2 : 2 mm Pitch Carrier Tape 20000 pcs H3 : 2 mm Pitch Carrier Tape 30000 pcs H4 : 2 mm Pitch Carrier Tape 40000 pcs H5 : 2 mm Pitch Carrier Tape 50000 pcs
				1% (4-Digit)			

3 Product Specifications:

Type	Rated Power at 70°C	Max. Working Voltage	Max. Overload Voltage	T.C.R. (ppm/°C)	Resistance Range	Number of Terminals	Number Of Resistors	JUMPER Rated Current	JUMPER Resistance Value
					F(±1%) J(±5%)				
FSA01-2V (0201)	1/32 W	12.5V	25V	+400/-200 ±250	10Ω ≤ R ≤ 100Ω	4	2	0.5A	100mΩ MAX.
					100Ω < R ≤ 1MΩ				
FSA01-4V (0201)	1/32 W	12.5V	25V	+400/-200 ±250	10Ω ≤ R ≤ 100Ω	8	4	0.5A	100mΩ MAX..
					100Ω < R ≤ 1MΩ				
Operating Temperature Range				-55°C ~ +155°C					

3.1 Power Derating Curve: Operating

Temperature Range : - 55 ~ +155 °C

For resistors operated in ambient temperatures 70°C, power rating shall be derated in accordance with the curve below:

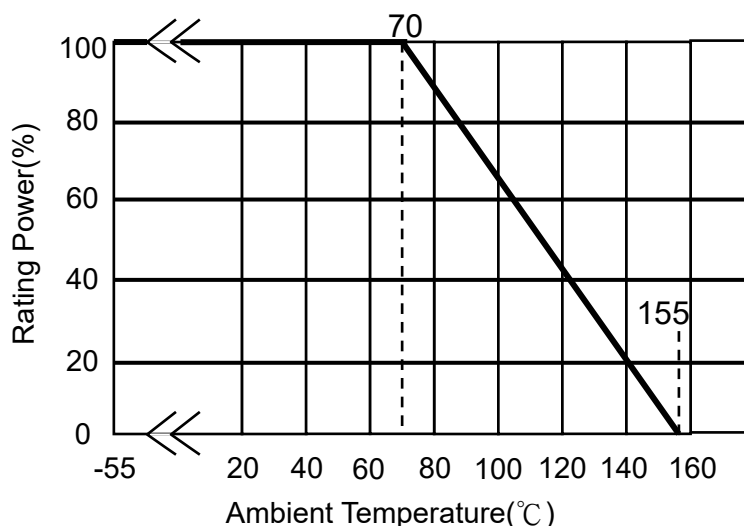

3.2 Rated Voltage:

3.2.1 Resistance Range: $\geq 1\Omega$

Rated Voltage: The resistor shall have a DC continuous working voltage or an rms. AC Continuous working voltage at commercial-line frequency and waveform corresponding to the power rating, as determined from the following:

$$E = \sqrt{R \times P}$$

E= Rated voltage (v)
P= Power rating (w)
R= Nominal resistance(Ω)

3.2.2 Resistance Range:(0 Ω)

Rated Current: The resistor shall have a DC continuous working current or a rms.AC continuous working current at commercial-line frequency and wave form corresponding to the power rating, as determined from the following:

$$I = \sqrt{P/R}$$

I= Rated current (A)
P= Power rating (w)
R= Nominal resistance(Ω)

4 Physical Dimensions:

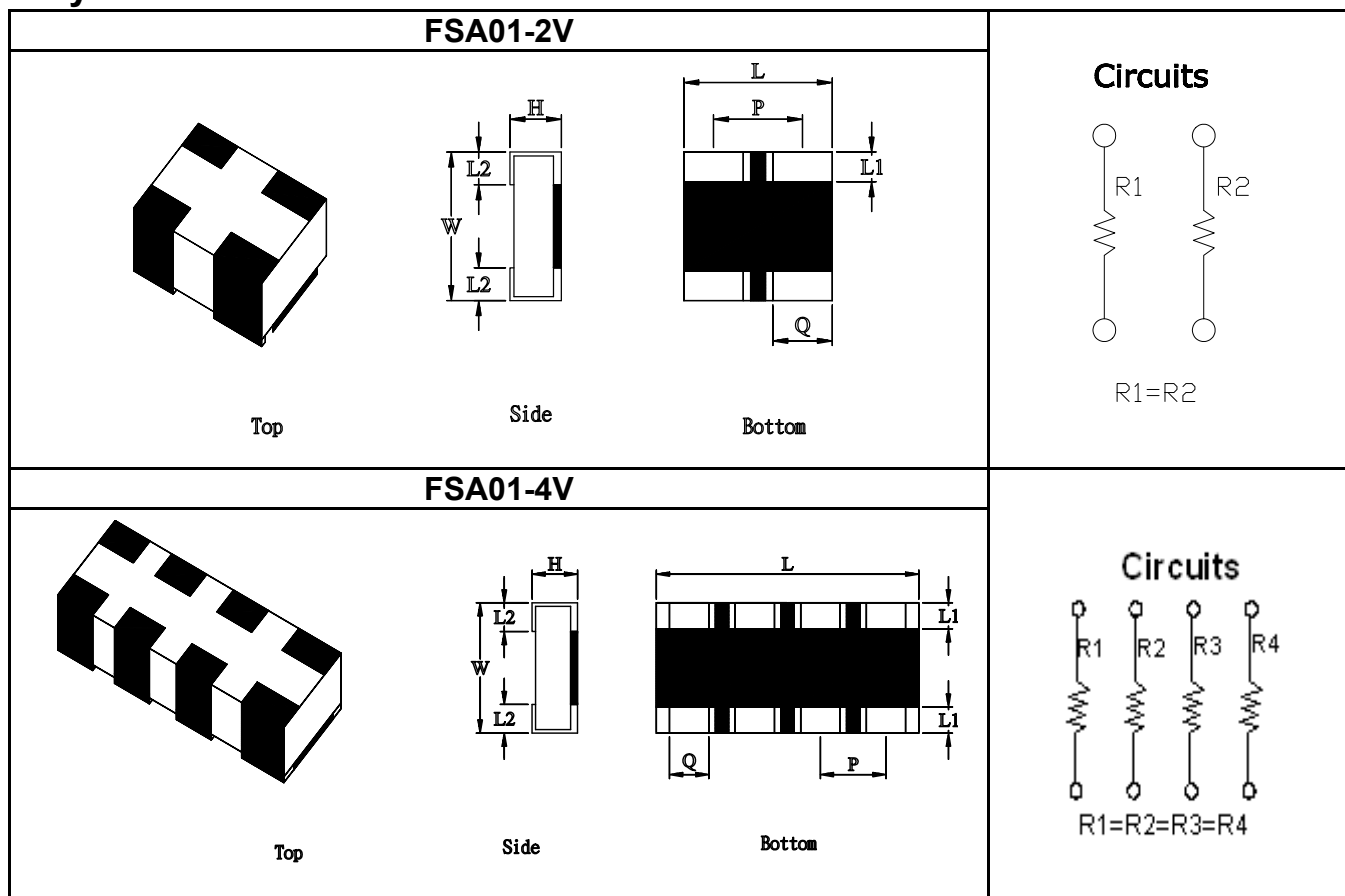

Type	Dimensions (mm)						
	L	W	H	L1	L2	P	Q
FSA01-2V (0201)	0.80±0.05	0.60±0.05	0.23±0.10	0.20+0.05 -0.10	0.10+0.10 -0.05	0.50±0.05	0.20±0.10
FSA01-4V (0201)	1.40±0.05	0.60±0.05	0.23±0.10	0.20+0.05 -0.10	0.10+0.10 -0.05	0.40±0.05	0.20±0.10

5 Structure Graph:

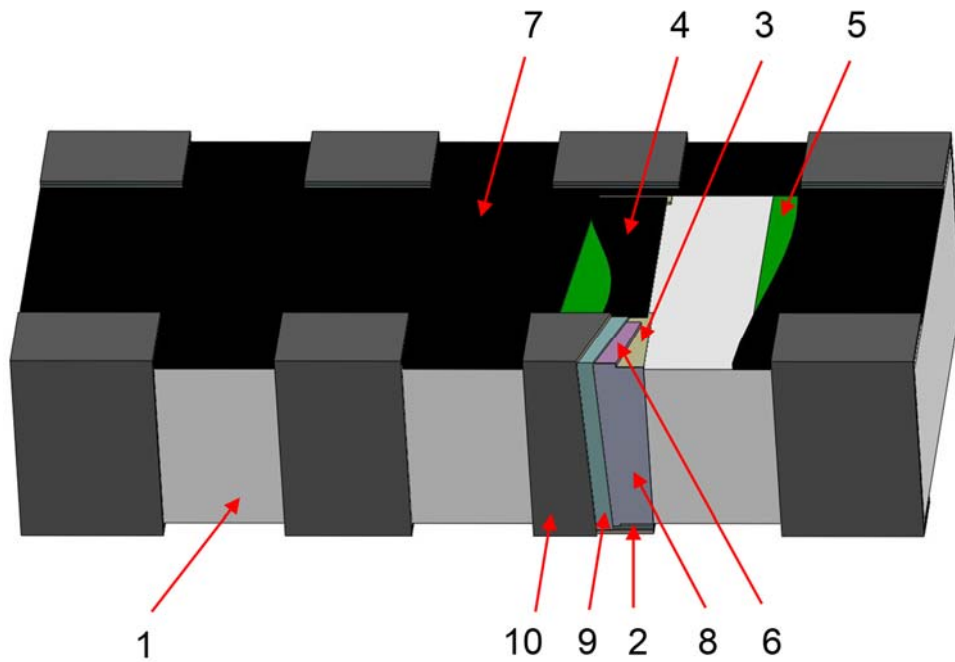

(Bottom Side)

1	Ceramic substrate	6	2nd Bottom inner electrode
2	Top inner electrode	7	2nd Protective coating
3	1st Bottom inner electrode	8	Terminal inner electrode
4	Resistive layer	9	Ni plating
5	1st Protective coating	10	Sn plating

6 Reliability Performance:

6.1 Electrical Performance Test

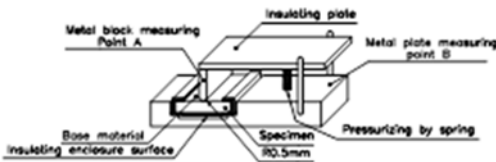
Item	Conditions	Specifications	
		Resistors	Jumper
Temperature Coefficient of Resistance	$TCR (ppm/^\circ C) = \frac{(R2 - R1)}{R1 (T2 - T1)} \times 10^6$ R1: Resistance at room temperature R2: Resistance at -55°C or +125°C T1: Room temperature T2: Temperature -55°C or +125°C Refer to JIS-C5201-1 4.8	Refer item 3. General Specifications	NA
Short Time Overload	Applied 2.5 times rated voltage for 5 seconds and release the load for about 30 minutes, then measure its resistance variance rate. (Rated voltage refer to item 3. general specifications) Refer to JIS-C5201-1 4.13	$\Delta R = \pm 2.0\%$	Refer to item 3. General Specifications
Insulation Resistance	Put the resistor in the fixture, add 100 VDC in +, - terminal for 60 sec then measured the insulation resistance between electrodes and insulating enclosure or between electrodes and base material. Refer to JIS-C5201-1 4.6 	$\geq 10^9 \Omega$	
Dielectric Withstand Voltage	Put the resistor in the fixture, add 300 VAC in +, - terminal for 60 sec. Refer to JIS-C5201-1 4.7	No short or burned on the appearance.	

6.2 Mechanical Performance Test

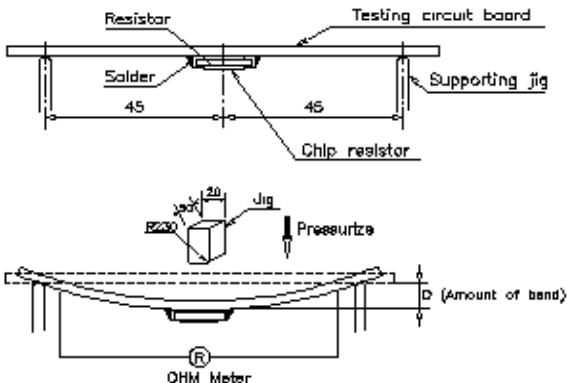
Item	Conditions	Specifications	
		Resistors	Jumper
Resistance to Solvent	The tested resistor be immersed into isopropyl alcohol of 20~25°C for 5 minutes, then the resistor is left in the room for 48 hr , then measure its resistance variance rate. Refer to JIS-C5201-1 4.29	$\Delta R = \pm 1.0\%$	Refer to item 3. General Specifications
Solderability	The resistor be immersed into solder pot in temperature 235±5°C for 2 sec, then the resistor is left as placed under microscope to observed its solder area. Refer to JIS-C5201-1 4.17	Solder coverage over 95%	
Resistance to Soldering Heat	◎Test method 1 (solder pot test): The tested resistor be immersed into molten solder of 260+5/-0°C for 10 seconds. Then the resistor is left in the room for 1 hour. ◎Test method 2 (solder pot test): The tested resistor be immersed into molten solder of 260+5/-0°C for 30 seconds. Then the resistor is left as placed under microscope to observe its solder area. Refer to JIS-C5201-1 4.18	Test item 1: (1).Variance rate on resistance $\Delta R = \pm 1.0\%$ Test item 2: (1).Solder coverage over 95%. (2).The underlying material (such as ceramic) shall not be visible at the crest corner area of the electrode.	Refer to item 3. General Specifications
Joint Strength of Solder	◎Bending Strength: Solder tested resistor on the PC board, add force in the middle down, and under load measure its resistance variance rate. D=3mm  Refer to JIS-C5201-1 4.33	$\Delta R = \pm 1.0\%$	Refer to item 3. General Specifications

6.3 Environmental Performance

Item	Conditions		Specifications									
			Resistors	Jumper								
Resistance to Dry Heat	Put tested resistors in chamber under temperature $155\pm 5^{\circ}\text{C}$ for $1,000\pm 4$ hours. Then leaving in room temperature for 60 minutes, and measure its resistance variance rate. Refer to JIS-C5201-1 4.25		$\Delta R = \pm 1.0\%$	Refer to item 3. General Specifications								
Thermal Shock	Put the tested resistor in the thermal shock chamber under the temperature cycle which shown in the following table shall be repeated 300 times consecutively. Then leaving the tested resistor in the room temperature for 1 hours, and measure its resistance variance rate. <table border="1" style="margin-left: 20px;"> <thead> <tr> <th colspan="2">Testing Condition</th> </tr> </thead> <tbody> <tr> <td>Lowest Temperature</td> <td>$-55\pm 5^{\circ}\text{C}$</td> </tr> <tr> <td>Highest Temperature</td> <td>$125\pm 5^{\circ}\text{C}$</td> </tr> <tr> <td>Temperature-retaining time</td> <td>15 minutes each</td> </tr> </tbody> </table> Refer to MIL-STD 202 Method 107		Testing Condition		Lowest Temperature	$-55\pm 5^{\circ}\text{C}$	Highest Temperature	$125\pm 5^{\circ}\text{C}$	Temperature-retaining time	15 minutes each	$\Delta R = \pm 1.0\%$	Refer to item 3. General Specifications
Testing Condition												
Lowest Temperature	$-55\pm 5^{\circ}\text{C}$											
Highest Temperature	$125\pm 5^{\circ}\text{C}$											
Temperature-retaining time	15 minutes each											
Loading Life in Moisture	Put the tested resistor in the chamber under temperature $40\pm 2^{\circ}\text{C}$, relative humidity 90~95% and load the rated voltage for 90 minutes on, 30 minutes off, total 1000 hours. Then leaving the tested resistor in room temperature for 60 minutes, and measure its resistance variance rate. Refer to JIS-C5201-1 4.24		$\Delta R = \pm 3.0\%$	Refer to item 3. General Specifications								
Load Life	Put the tested resistor in chamber under temperature $70\pm 2^{\circ}\text{C}$ and load the rated voltage for 90 minutes on, 30 minutes off, total 1000 hours. Then leaving the tested resistor in room temperature for 60 minutes, and measure its resistance variance rate. Refer to JIS-C5201-1 4.25		$\Delta R = \pm 3.0\%$	Refer to item 3. General Specifications								
Sulfuration Test	Class B	Put the tested resistor in sulfur vapor, at a temperature of $105\pm 2^{\circ}\text{C}$ for 750hrs Refer to ASTM-B-809-95&EIA977	$\Delta R = \pm 4.0\%$	Refer to item 3. General Specifications								

7 Plating Thickness:

7.1 Ni : $\geq 2 \mu\text{m}$

7.2 Sn(Tin) : $\geq 3 \mu\text{m}$

7.3 Sn(Tin) : Matte Sn

8 Rule of package empty quantity:

8.1 Empty quantity for each reels not allowed to exceed 0.1% of the whole quantity, and continuous 2pcs (included) empty are also unallowed.

9 Technical application notes: (This is for recommendation, please customer perform adjustment according to actual application)

9.1 Recommend Soldering Method:

9.1.1 Lead Free Reflow Soldering Profile(MEET J-STD-020D)

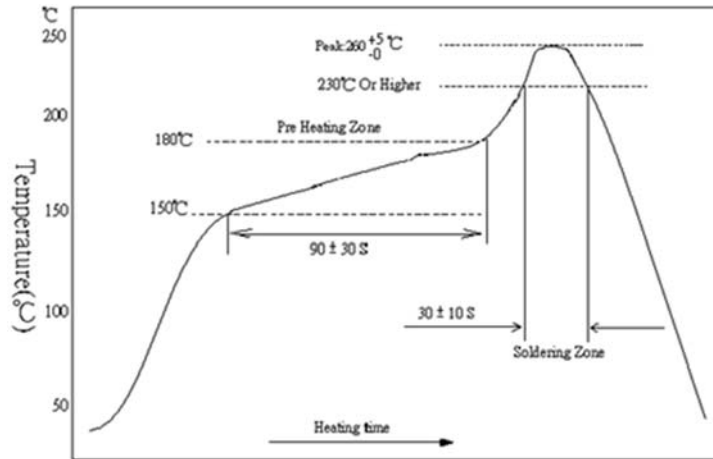

Remark: The peak temperature of soldering heat is 260 +5/-0 °C for 10 seconds.

9.1.2 Soldering Iron: temperature 350°C±10°C , dwell time shall be less than 3 sec.

9.2 Recommend Land Pattern Design (For Reflow Soldering):

When a component is soldered, the resistance after soldering changes slightly depending on the size of the soldering area and the amount of soldering. When designing a circuit, it is necessary to consider the effect of a decrease or increase in its resistance.

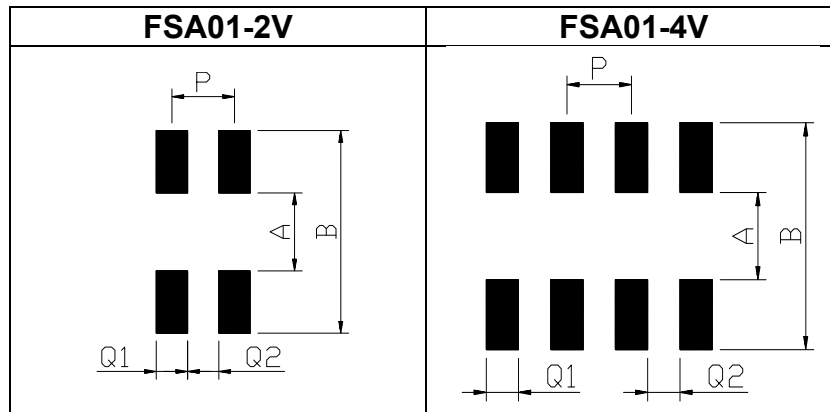

Type	Dimensions (mm)				
	A	B	P	Q1	Q2
FSA01-2V	0.30	0.90	0.50	0.30	0.20
FSA01-4V	0.30	0.90	0.40	0.20	0.20

9.3

9.4 Environment Precautions:

This specification product is for general electronic use, RALEC will not be responsible for any damage, cost or loss caused by using this specification product in any special environment. If other applications need to confirm with RALEC.

If consumer intends to use our Company product in special environment or condition (including but not limited to those mentioned below), then will need to make individual recognition of product features and reliability accordingly.

- (a) Used in high temperature and humidity environment
- (b) Exposed to sea breeze or other corrosive gas, such as Cl₂、H₂S、NH₃、SO₂ and NO₂.
- (c) Used in non-verified liquids including water, oil, chemical and organic solvents.
- (d) Using non-verified resin or other coating material to seal or coat our Company product.
- (e) After soldering, it is necessary to use water-soluble detergents to clean residual solder fluxes, even though no-clean fluxes are recommended.

9.5 Momentary Overload Precautions:

The product might be out of function when momentary overloaded. Please make sure to avoid momentary overloading while using and preserving.



9.6 Operation and Processing Precautions:

- (a) Avoid damage to the edge of resistor and protective layer caused by mechanical stress.
- (b) Handle with care when printing circuit board (PCB) is divided or fixed on support body, because bending of printing circuit board (PCB) mounting will make mechanical stress for resistors.
- (c) Make sure the power rating is under the limit when using the resistor. When power rating is over the limit, the resistor will be overloaded. There might be machinery damage due to the climbing temperature.
- (d) If the resistor will be exposed under massive impact load (shock wave) in a short period of time, the working environment must be set up well before use.
- (e) Please make evaluation and confirmation when the product is well used in your company and have a through consideration of it's fail-safe design to ensure the system safety.

10 Storage and transportation requirement:

- 10.1 The temperature condition must be controlled at $25 \pm 5^{\circ}\text{C}$, the R.H. must be controlled at $60 \pm 15\%$. The stock can maintain quality level in two years.
- 10.2 Please avoid the mentioned harsh environment below when storing to ensure product performance and its' weldability. Places exposed to sea breeze or other corrosive gas, such as Cl_2 、 H_2S 、 NH_3 、 SO_2 and NO_2 .
- 10.3 When the product is moved and stored, please ensure the correct orientation of the box. Do not drop or squeeze the box. Otherwise, the electrode or the body of the product may be damaged.

11 The carton packaged for electronic-information products is made by the symbol as follows: (For china)

	
<p>Marking for control of pollution cause by electronic-information products</p>	<p>Marking for package recovery</p>

12 Attachments

- 12.1 Document Revise Record (QA-QR-027)

Legal disclaimer

RALEC, its distributors and agents (collectively, "RALEC"), hereby disclaims any and all liabilities for any errors, inaccuracies or incompleteness contained in any product related information, including but not limited to product specifications, datasheets, pictures and/or graphics. RALEC may make changes, modifications and/or improvements to product related information at any time and without notice.

RALEC makes no representation, warranty, and/or guarantee about the fitness of its products for any particular purpose or the continuing production of any of its products. To the maximum extent permitted by law, RALEC disclaims (i) any and all liability arising out of the application or use of any RALEC product, (ii) any and all liability, including without limitation special, consequential or incidental damages, and (iii) any and all implied warranties, including warranties of fitness for a particular purpose, non-infringement and merchantability.

RALEC defined this product is for general electrical use , not design for any application for automotive electrical ,life-saving or life support equipment, or any application which may inflict casualties if RALEC product failure occurred. When consumer is using or selling products of RALEC without having discussion with the sales representatives and specifically stated the applicability mentioned above in a written form, then the client need to take a full responsibility and agree to protect RALEC from punishment and damage.

Information provided here is intended to indicate product specifications only. RALEC reserves all the rights for revising this content without further notification, as long as products are unchanged. Any product change will be announced by ECN.