

1 Scope:

- 1.1 This specification is applicable to fully lead-free and halogen-free of RoHS directive for FTR series precision thick film chip resistors.
- 1.2 Fully lead-free products without RoHS exemptions.
- 1.3 The product is for general electronic purpose.

2 Explanation Of Part Numbers:

(EX)

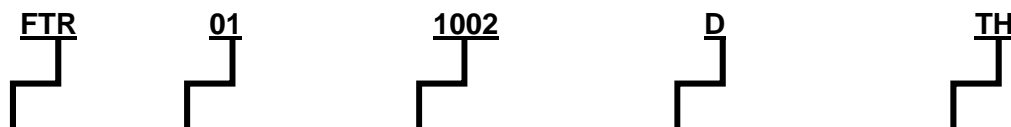

Type	Size	Nominal Resistance		Resistance Tolerance	Packaging(Refer to IE-SP-055)
Fully lead-free Precision Thick Film Chip Resistors	01(0201) 02(0402) 03(0603) 05(0805) 06(1206) 12(1210) 20(2010) 25(2512)	0.1% 0.5% 1% (4-Digit)	EX. 10.2Ω=10R2 10KΩ=1002	B=± 0.1% D=± 0.5% F=± 1%	Q1 : 1 mm Pitch Carrier Tape 20000 pcs QE : 1mm Pitch Carrier Tape 150000 pcs TH : 2 mm Pitch Carrier Tape 10000 pcs H0 : 2 mm Pitch Carrier Tape 15000 pcs H1 : 2 mm Pitch Carrier Tape 20000 pcs H2 : 2 mm Pitch Carrier Tape 20000 pcs H3 : 2 mm Pitch Carrier Tape 30000 pcs H4 : 2 mm Pitch Carrier Tape 40000 pcs H5 : 2 mm Pitch Carrier Tape 50000 pcs H6 : 2 mm Pitch Carrier Tape 60000 pcs TP : 4 mm Pitch Carrier Tape 5000 pcs P2 : 4 mm Pitch Carrier Tape 10000 pcs P3 : 4 mm Pitch Carrier Tape 15000 pcs P4 : 4 mm Pitch Carrier Tape 20000 pcs TE : 4 mm Pitch Carrier Tape 4000 pcs

RD		QA		Remark IT'S NOT UNDER CONTROL FOR PDF FILE PLS NOTE THE VERSION STATED.	Issue Dep. DATA Center.
Written 向燕	Checked 	Approved 王嘉平	Signing 		
				Do not copy without permission	Series No. 60

3 General Specifications:

Type	Rated Power at 70°C	Max. Working Voltage	Max. Overload Voltage	T.C.R (ppm/°C)	Resistance Range	
					B(±0.1%)、D(±0.5%) E-24、E-96	F(±1.0%) E-24、E-96
FTR01 (0201)	$\frac{1}{20}$ W	30V	60V	±150	-----	27Ω ≤ R < 100Ω
				±100	100Ω ≤ R ≤ 1MΩ	100Ω ≤ R ≤ 1MΩ
FTR02 (0402)	$\frac{1}{16}$ W	50V	100V	±75	100Ω ≤ R ≤ 1MΩ	100Ω ≤ R ≤ 1MΩ
				±100	-----	1Ω ≤ R < 100Ω
FTR03 (0603)	$\frac{1}{10}$ W	75V	150V	±75	100Ω ≤ R ≤ 1MΩ	100Ω ≤ R ≤ 1MΩ
				±100	-----	1Ω ≤ R < 100Ω
FTR05 (0805)	$\frac{1}{8}$ W	150V	300V	±50	100Ω ≤ R ≤ 1MΩ	100Ω ≤ R ≤ 1MΩ
				±100	-----	1Ω ≤ R < 100Ω
FTR06 (1206)	$\frac{1}{4}$ W	200V	400V	±50	100Ω ≤ R ≤ 1MΩ	100Ω ≤ R ≤ 1MΩ
				±100	-----	1Ω ≤ R < 100Ω
FTR12 (1210)	$\frac{1}{2}$ W	200V	400V	±50	100Ω ≤ R ≤ 1MΩ	100Ω ≤ R ≤ 1MΩ
				±100	-----	1Ω ≤ R < 100Ω
FTR20 (2010)	$\frac{3}{4}$ W	200V	400V	±50	100Ω ≤ R ≤ 1MΩ	100Ω ≤ R ≤ 1MΩ
				±100	-----	1Ω ≤ R < 100Ω
FTR25 (2512)	1W	200V	400V	±50	100Ω ≤ R ≤ 1MΩ	100Ω ≤ R ≤ 1MΩ
				±100	-----	1Ω ≤ R < 100Ω
Operating Temperature Range				-55°C ~ +155°C (0201: -55°C ~ +125°C)		

Remark

IT'S NOT UNDER CONTROL FOR PDF FILE
PLS NOTE THE VERSION STATED.

Issue Dep. **DATA Center.**

Do not copy without permission

Series No. **60**

3.1 Power Derating Curve:

Type	FTR01 (0201)	Other
Operating Temperature Range	-55°C ~ +125°C	-55°C ~ +155°C
Explain	If the ambient temperature exceeds 70 degrees centigrade to 125 degrees centigrade, the power can be modified by the curve as below.	If the ambient temperature exceeds 70 degrees centigrade to 155 degrees centigrade, the power can be modified by the curve as below.
Figure		

3.2 Voltage Rating:

Rated Voltage: DC voltage or AC voltage (rms) based on the rated power.

The voltage can be calculated by the following formula. If the calculated value exceeds the Max voltage specified in the Table 3, the Max voltage rating is set as the voltage rating.

$$E = \sqrt{R \times P}$$

E= Rated voltage(V)

P= Power rating(W)

R= Nominal resistance(Ω)

Remark

IT'S NOT UNDER CONTROL FOR PDF FILE
PLS NOTE THE VERSION STATED.

Issue Dep. **DATA Center.**

Do not copy without permission

Series No. **60**

4 Dimensions:

Unit:mm

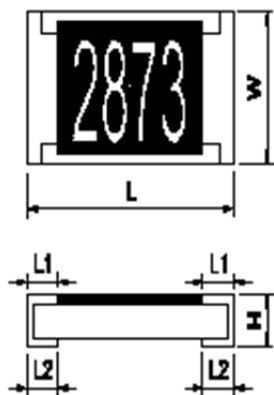

Dimension		L	W	H	L1	L2
Type	Size Code					
FTR01	0201	0.60±0.03	0.30±0.03	0.23±0.03	0.15±0.05	0.12±0.05
FTR02	0402	1.00±0.10	0.50±0.05	0.30±0.05	0.15±0.10	0.25±0.10
FTR03	0603	1.60±0.10	0.80±0.10	0.45±0.10	0.25±0.15	0.30±0.15
FTR05	0805	2.00±0.10	1.25±0.10	0.50±0.10	0.35±0.20	0.35±0.15
FTR06	1206	3.05±0.10	1.55±0.10	0.50±0.10	0.45±0.20	0.35±0.15
FTR12	1210	3.05±0.10	2.55±0.10	0.55±0.10	0.50±0.20	0.50±0.20
FTR20	2010	5.00±0.20	2.50±0.20	0.55±0.10	0.50±0.20	0.60±0.20
FTR25	2512	6.30±0.20	3.20±0.20	0.55±0.10	0.60±0.20	0.60±0.20

5 Structure Graph:

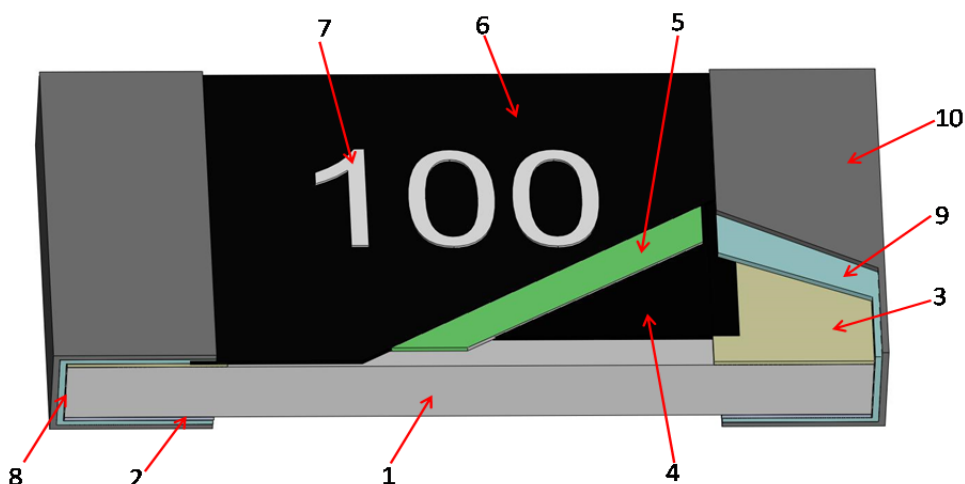

1	Ceramic substrate	6	2nd Protective coating
2	Bottom inner electrode	7	Marking
3	Top inner electrode	8	Terminal inner electrode
4	Resistive layer	9	Ni plating
5	1st Protective coating	10	Sn plating

Remark

IT'S NOT UNDER CONTROL FOR PDF FILE
PLS NOTE THE VERSION STATED.

Do not copy without permission

Issue Dep. DATA Center.

Series No. 60

6 Reliability Test:

6.1 Electrical Performance Test

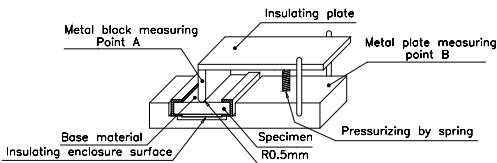
Item	Conditions	Specifications
		Resistors
Temperature Coefficient of Resistance	$TCR (ppm/^{\circ}C) = \frac{(R2 - R1)}{R1 (T2 - T1)} \times 10^6$ R1: Resistance at room temperature R2: Resistance at +125°C T1: Room temperature T2: Temperature +125°C Refer to JIS-C5201-1 4.8	Refer to item 3. general specifications
Short Time Overload	Applied 2.5 times rated voltage for 5 seconds and release the load for about 30 minutes , then measure its resistance variance rate.(Rated voltage refer to item 3. general specifications) Refer to JIS-C5201-1 4.13	ΔR%=±1.0%
Insulation Resistance	Put the resistor in the fixture, add 100 VDC in + , - terminal for 60 sec then measured the insulation resistance between electrodes and insulating enclosure or between electrodes and base material. Refer to JIS-C5201-1 4.6 	≥ 10 ⁹ Ω
Dielectric Withstand Voltage	Put the resistor in the fixture, add VAC (see SPEC below) in + , - terminal for FTR01 、 02 、 03 apply 300 VAC 1 minute. FTR05 、 06 、 12 、 20 、 25 apply 500 VAC 1 minute. Refer to JIS-C5201-1 4.7	No short or burned on the appearance.
Intermittent Overload	Put the tested resistor in chamber and load 2.5 times rated DC voltage for 1 sec on, 25 sec off, the total of 10000+400/-0 test cycles, then it be left at no-load for 1 hour , then measure its resistance variance rate. Refer to JIS-C5201-1 4.13	ΔR%=±5.0%

Remark

IT'S NOT UNDER CONTROL FOR PDF FILE
PLS NOTE THE VERSION STATED.

Issue Dep. **DATA Center.**

Do not copy without permission

Series No. **60**

6.2 Mechanical Performance Test

Item	Conditions	Specifications
		Resistors
Terminal Strength	<p>Test1:The resistor mounted on the board applied 5N pushing force on the sample rear for 10 sec. (FTR01:3N)</p> <p>Test2:The resistor mounted on the board, slowly add force on the sample rear until the sample termination is breakdown.</p> <p>Refer to JIS-C5201-1 4.16</p>	<p>Test1:No evidence of mechanical damage.</p> <p>Test2:FTR01 \geq 3N Other Type \geq 5N</p>
Resistance to Solvent	<p>The tested resistor be immersed into isopropyl alcohol of 20~25°C for 5\pm0.5 minutes, then the resistor is left in the room for 48 hrs., and measured its resistance variance rate.</p> <p>Refer to JIS-C5201-1 4.29</p>	<p>$\Delta R\% = \pm 0.5\%$</p>
Solderability	<p>Preconditioning: Put the tested resistor in the apparatus of PCT, at a temperature of 105°C, humidity of 100% RH, and pressure of 1.22\times10⁵ Pa for a duration of 4 hours. Then after left the tested resistor in room temperature for 2 hours or more.</p> <p>Test method: The resistor be immersed into solder pot in temperature 235\pm3°C for 2\pm0.5 sec, then the resistor is left as placed under microscope to observed its solder area.</p> <p>Refer to JIS-C5201-1 4.17</p>	<p>Solder coverage over 95%</p>
Resistance to Soldering Heat	<p>◎Test method 1 (solder pot test): The tested resistor be immersed into molten solder of 260+5/-0°C for 10+1/-0 seconds. Then the resistor is left in the room for 1 hour.</p> <p>◎Test method 2 (solder pot test): The tested resistor be immersed into molten solder of 260+5/-0°C for 30+1/-0 seconds. Then the resistor is left as placed under microscope to observe its solder area.</p> <p>◎Test method 3 (Electric iron test): Preheating temperature : 350\pm10°C Electric iron preheating time : 3+1/-0 sec Preheating the electric iron on electrode termination, as after that step placed the iron over 60 min. and measured its resistance variance rate.</p> <p>Refer to JIS-C5201-1 4.18</p>	<p>Test item 1: (1).Variance rate on resistance $\Delta R\% = \pm 1.0\%$</p> <p>Test item 2: (1).Solder coverage over 95%. (2).The underlying material (such as ceramic) shall not be visible at the crest corner area of the electrode.</p> <p>Test item 3: (1).Variance rate on resistance $\Delta R\% = \pm 1.0\%$</p>

Remark

IT'S NOT UNDER CONTROL FOR PDF FILE
PLS NOTE THE VERSION STATED.

Issue Dep. **DATA Center.**

Do not copy without permission

Series No. **60**

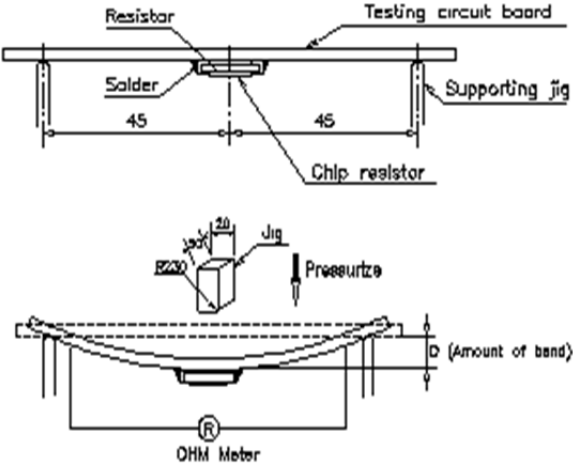
Item	Conditions	Specifications
		Resistors
Joint Strength of Solder	<p>◎Bending Strength: Solder tested resistor on to PC board. Add force in the middle down, and under load measured its resistance variance rate. D:FTR02、03、05=5mm FTR01、06、12=3mm FTR20、25=2mm</p>  <p>Refer to JIS-C5201-1 4.33</p>	<p>$\Delta R\% = \pm 1.0\%$</p>

Remark

IT'S NOT UNDER CONTROL FOR PDF FILE
PLS NOTE THE VERSION STATED.

Do not copy without permission

Issue Dep. **DATA Center.**

Series No. **60**

6.3 Environmental Test

Item	Conditions	Specifications								
		Resistors								
Resistance to Dry Heat	Put tested resistor in chamber under temperature $155\pm 5^{\circ}\text{C}$ for 1000 +48/-0 hours. Then leaving the tested resistor in room temperature for 60 minutes, and measure its resistance variance rate. Refer to JIS-C5201-1 4.25	$\Delta R\% = \pm 1.0\%$								
Thermal Shock	Put chip resistors in the thermal shock machine ,and the temperature was -55°C for 15 minutes and $+125^{\circ}\text{C}$ for 15 minutes, the total of 300 times and then removed, let stand for more than 1 hour before measuring the resistance change rate <table border="1" style="margin-left: 20px;"> <thead> <tr> <th colspan="2">Testing Condition</th> </tr> </thead> <tbody> <tr> <td>Lowest Temperature</td> <td>$-55\pm 5^{\circ}\text{C}$</td> </tr> <tr> <td>Highest Temperature</td> <td>$125\pm 5^{\circ}\text{C}$</td> </tr> <tr> <td>Temperature-retaining time</td> <td>15 minutes each</td> </tr> </tbody> </table> Refer to MIL-STD 202 Method 107	Testing Condition		Lowest Temperature	$-55\pm 5^{\circ}\text{C}$	Highest Temperature	$125\pm 5^{\circ}\text{C}$	Temperature-retaining time	15 minutes each	$\Delta R\% = \pm 0.5\%$
Testing Condition										
Lowest Temperature	$-55\pm 5^{\circ}\text{C}$									
Highest Temperature	$125\pm 5^{\circ}\text{C}$									
Temperature-retaining time	15 minutes each									
Loading Life in Moisture	Put the tested resistor in the chamber under temperature $40\pm 2^{\circ}\text{C}$, relative humidity 90~95% and load the rated voltage for 90 minutes on, 30 minutes off, total 1000 hours. Then leaving the tested resistor in room temperature for 60 minutes, and measure its resistance variance rate Refer to JIS-C5201-1 4.24	FTR01: $\Delta R\% = \pm 1.5\%$ Other Type: $\Delta R\% = \pm 1.0\%$								
Load Life	Put the tested resistor in chamber under temperature $70\pm 2^{\circ}\text{C}$ and load the rated voltage for 90 minutes on, 30 minutes off, total 1000 hours. Then leaving the tested resistor in room temperature for 60 minutes, and measure its resistance variance rate. Refer to JIS-C5201-1 4.25	FTR01: $\Delta R\% = \pm 1.5\%$ Other Type: $\Delta R\% = \pm 1.0\%$								

Remark

IT'S NOT UNDER CONTROL FOR PDF FILE
PLS NOTE THE VERSION STATED.

Issue Dep. **DATA Center.**

Do not copy without permission

Series No. **60**

7 Measurement Point :

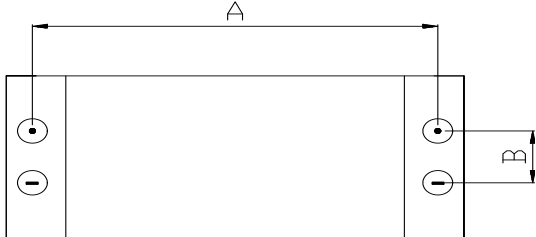
Bottom electrode		Unit : mm		
		DIM		
		TYPE	A	B
⊙	Current Terminal	FTR01	0.44±0.05	0.22±0.05
⊖	Voltage Terminal	FTR02	0.80±0.05	0.24±0.05
		FTR03	1.35±0.05	0.35±0.05
		FTR05	1.80±0.05	0.35±0.05
		FTR06	2.90±0.05	0.35±0.05
		FTR12	2.90±0.05	0.35±0.05
		FTR20	4.50±0.05	1.15±0.05
		FTR25	5.90±0.05	1.60±0.05

8 Plating Thickness :

8.1 Ni: $\geq 2\mu\text{m}$

8.2 Sn(Tin): $\geq 3\mu\text{m}$

8.3 Sn(Tin):Matte Sn

Remark

IT'S NOT UNDER CONTROL FOR PDF FILE
PLS NOTE THE VERSION STATED.

Issue Dep. **DATA Center.**

Do not copy without permission

Series No. **60**

9 Technical application notes:(This is a recommendation, please adjust it according to actual application)

9.1 Recommend Soldering Method:

9.1.1 Lead Free IR Reflow Soldering Profile

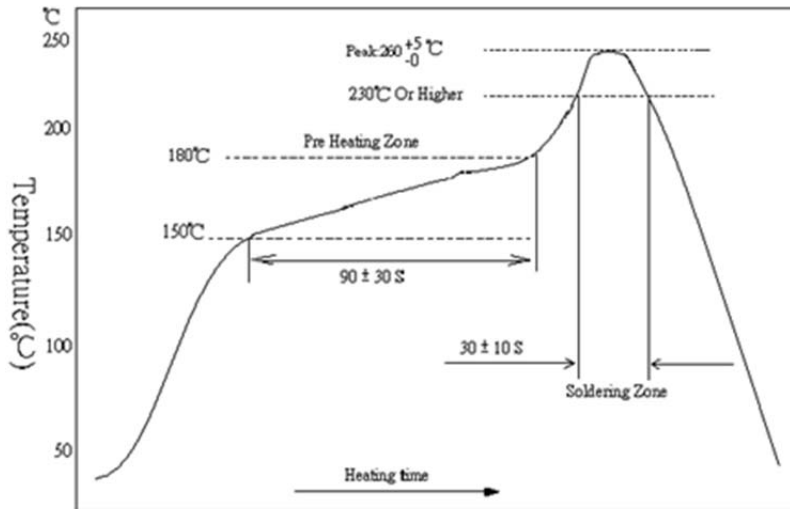

Remark: The peak temperature of soldering heat is $260 \pm 5/-0^{\circ}\text{C}$ for 10 seconds.

9.1.2 Lead Free Double-Wave Soldering Profile(Applicable to products above 0603(inclusive))

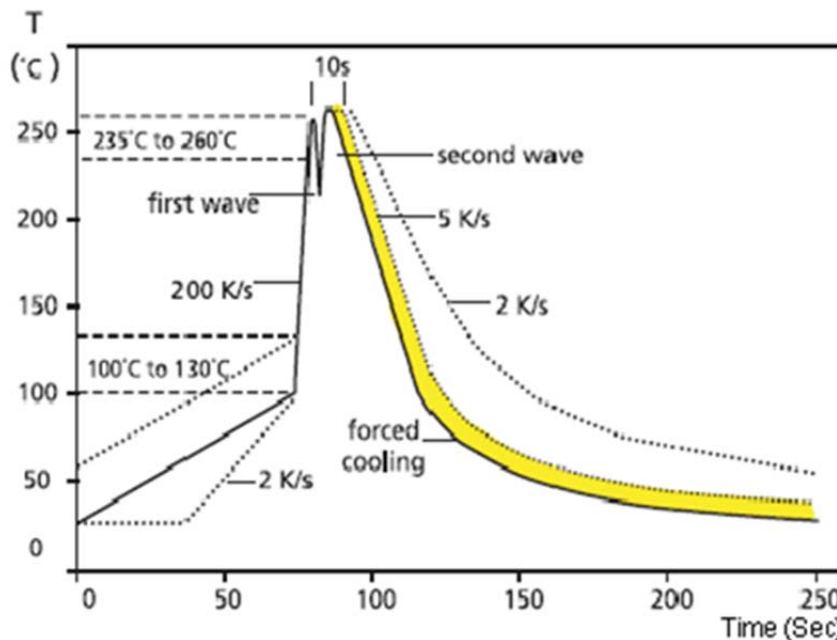

9.1.3 Soldering Iron: temperature $350 \pm 10^{\circ}\text{C}$, dwell time shall be less than 3 sec.

Remark

IT'S NOT UNDER CONTROL FOR PDF FILE
PLS NOTE THE VERSION STATED.

Issue Dep. **DATA Center.**

Do not copy without permission

Series No. **60**

9.2 Land Pattern Design (For Reflow Soldering) :

When a component is soldered, the resistance after soldering changes slightly depending on the size of the soldering area and the amount of soldering. When designing a circuit, it is necessary to consider the effect of a decrease or increase in its resistance.

Unit:mm

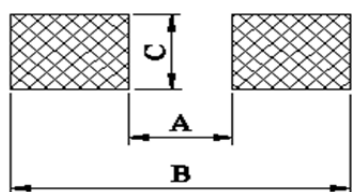

TYPE	DIM		
	A	B	C
FTR01	0.3	1.0	0.4
FTR02	0.5	1.5	0.6
FTR03	0.8	2.1	0.9
FTR05	1.2	3.0	1.3
FTR06	2.2	4.2	1.6
FTR12	2.2	4.2	2.8
FTR20	3.5	6.1	2.8
FTR25	3.8	8.0	3.5

9.3 Environment Precautions:

This specification product is for general electronic use, RALEC will not be responsible for any damage, cost or loss caused by using this specification product in any special environment. If other applications, you need to confirm with RALEC.

If consumer intends to use our Company product in special environment or condition (including but not limited to those mentioned below), then will need to make individual recognition of product features and reliability accordingly.

- (a) Used in high temperature and humidity environment.
- (b) Exposed to sea breeze or other corrosive gas, such as Cl₂、H₂S、NH₃、SO₂ and NO₂.
- (c) Used in non-verified liquids including water, oil, chemical and organic solvents.
- (d) Using non-verified resin or other coating material to seal or coat our Company product.
- (e) After soldering, it is necessary to use water-soluble detergents to clean residual solder fluxes, even though no-clean fluxes are recommended.

9.4 Momentary Overload Precautions:

The product might be out of function when momentary overloaded. Please make sure to avoid momentary overloading while using and preserving

Remark

IT'S NOT UNDER CONTROL FOR PDF FILE
PLS NOTE THE VERSION STATED.

Issue Dep. **DATA Center.**

Do not copy without permission

Series No. **60**

RALEC 旺詮	FTR Series Thick Film Chip Resistors Product Specification	Document No.	IE-SP-196
		Released Date	2020/12/25
		Page No	12

9.5 Operation and Processing Precautions:

- (a) Avoid damage to the edge of resistor and protective layer caused by mechanical stress.
- (b) Handle with care when printing circuit board (PCB) is divided or fixed on support body, because bending of printing circuit board (PCB) mounting will make mechanical stress for resistors.
- (c) Make sure the power rating is under the limit when using the resistor. When power rating is over the limit, the resistor will be overloaded. There might be machinery damage due to the climbing temperature.
- (d) If the resistor will be exposed under massive impact load (shock wave) in a short period of time, the working environment must be set up well before use.
- (e) Please make evaluation and confirmation when the product is well used in your company and have a through consideration of it's fail-safe design to ensure the system safety.



10 Stock period:

- 10.1 The temperature condition must be controlled as $25\pm 5^{\circ}\text{C}$, the R.H. must be controlled as $60\pm 15\%$. The stock can maintain quality level in two years.
- 10.2 Please avoid the mentioned harsh environment below when storing to ensure product performance and its weldability. Places exposed to sea breeze or other corrosive gas such as Cl_2 、 H_2S 、 NH_3 、 SO_2 and NO_2 .
- 10.3 When the product is moved and stored, please ensure the correct orientation of the box. Do not drop or squeeze the box. Otherwise, the electrode or the body of the product may be damaged.

Remark	IT'S NOT UNDER CONTROL FOR PDF FILE PLS NOTE THE VERSION STATED.	Issue Dep. DATA Center.
	Do not copy without permission	Series No. 60

RALEC 旺詮	FTR Series Thick Film Chip Resistors Product Specification	Document No.	IE-SP-196
		Released Date	2020/12/25
		Page No	13

11 The carton packaged for electronic-information products is made by the symbol as follows: (For china)

	
Marking for control of pollution cause by electronic-information products	Marking for package recovery

12 Attachments:

12.1 Document Revise Record(QA-QR-027)

Remark	IT'S NOT UNDER CONTROL FOR PDF FILE PLS NOTE THE VERSION STATED.	Issue Dep. DATA Center.
	Do not copy without permission	Series No. 60

RALEC 旺詮	FTR Series Thick Film Chip Resistors Product Specification	Document No.	IE-SP-196
		Released Date	2020/12/25
		Page No	14

Legal disclaimer

RALEC, its distributors and agents (collectively, "RALEC"), hereby disclaims any and all liabilities for any errors, inaccuracies or incompleteness contained in any product related information, including but not limited to product specifications, datasheets, pictures and/or graphics. RALEC may make changes, modifications and/or improvements to product related information at any time and without notice.

RALEC makes no representation, warranty, and/or guarantee about the fitness of its products for any particular purpose or the continuing production of any of its products. To the maximum extent permitted by law, RALEC disclaims (i) any and all liability arising out of the application or use of any RALEC product, (ii) any and all liability, including without limitation special, consequential or incidental damages, and (iii) any and all implied warranties, including warranties of fitness for a particular purpose, non-infringement and merchantability.

RALEC defined this product is for general electrical use , not design for any application for automotive electrical ,life-saving or life support equipment, or any application which may inflict casualties if RALEC product failure occurred. When consumer is using or selling products of RALEC without having discussion with the sales representatives and specifically stated the applicability mentioned above in a written form, then the client need to take a full responsibility and agree to protect RALEC from punishment and damage.

Information provided here is intended to indicate product specifications only. RALEC reserves all the rights for revising this content without further notification, as long as products are unchanged. Any product change will be announced by ECN.

Remark	IT'S NOT UNDER CONTROL FOR PDF FILE PLS NOTE THE VERSION STATED.	Issue Dep. DATA Center.
	Do not copy without permission	Series No. 60