

RTV Series Thick Film Chip Resistors Product Specification

Document No.	IE-SP-038
Released Date	2021/07/09
Page No.	1

1 Scope:

- 1.1 This specification is applicable to lead free and halogen free of RoHS directive for RTV series high voltage thick film chip resistors
- 1.2 The product is for general electronic purpose.

2 Explanation Of Part Numbers:

(EX)

	RTV		03		100		J		TP
Type	Size	Nominal Resistance		Resistance Tolerance	Packaging(Refer to IE-SP-055)				
High Voltage Thick Film Chip Resistors	03(0603) 05(0805) 06(1206) 12(1210) 20(2010) 25(2512)	5% (3-Digit)	EX. 10Ω=100 4.7Ω=4R7	D=± 0.5% F=± 1% J=± 5%	H4 : 2 mm Pitch Carrier Tape 40000 pcs TP : 4 mm Pitch Carrier Tape 5000 pcs P2 : 4 mm Pitch Carrier Tape 10000 pcs P3 : 4 mm Pitch Carrier Tape 15000 pcs P4 : 4 mm Pitch Carrier Tape 20000 pcs TE : 4 mm Pitch Carrier Tape 4000 pcs BA : 散裝(盒裝)				
	0.5% 1% (4-Digit)	EX. 10.2Ω=10R2 10KΩ=1002							

3 General Specifications:

Type	Rated Power at 70°C	Max. Working Voltage	Max. Overload Voltage	T.C.R (ppm/°C)	Resistance Range		
					D(±0.5%) E-96	F(±1%) E-96	J(±5%) E-24
RTV03 (0603)	1/10 W	350V	500V	±100	10Ω ≤ R ≤ 1MΩ	10Ω ≤ R ≤ 1MΩ	10Ω ≤ R ≤ 1MΩ
				±200	1Ω ≤ R < 10Ω 1MΩ < R ≤ 10MΩ	1Ω ≤ R < 10Ω 1MΩ < R ≤ 10MΩ	1Ω ≤ R < 10Ω 1MΩ < R ≤ 10MΩ
RTV05 (0805)	1/8 W	400V	800V	±100	10Ω ≤ R ≤ 1MΩ	10Ω ≤ R ≤ 1MΩ	10Ω ≤ R ≤ 1MΩ
				±200	1Ω ≤ R < 10Ω 1MΩ < R ≤ 27MΩ	1Ω ≤ R < 10Ω 1MΩ < R ≤ 27MΩ	1Ω ≤ R < 10Ω 1MΩ < R ≤ 27MΩ
RTV06 (1206)	1/4 W	500V	1000V	±100	10Ω ≤ R ≤ 1MΩ	10Ω ≤ R ≤ 1MΩ	10Ω ≤ R ≤ 1MΩ
				±200	1Ω ≤ R < 10Ω 1MΩ < R ≤ 27MΩ	1Ω ≤ R < 10Ω 1MΩ < R ≤ 27MΩ	1Ω ≤ R < 10Ω 1MΩ < R ≤ 27MΩ
RTV12 (1210)	1/2 W	500V	1000V	±100	10Ω ≤ R ≤ 1MΩ	10Ω ≤ R ≤ 1MΩ	10Ω ≤ R ≤ 1MΩ
				±200	1Ω ≤ R < 10Ω 1MΩ < R ≤ 27MΩ	1Ω ≤ R < 10Ω 1MΩ < R ≤ 27MΩ	1Ω ≤ R < 10Ω 1MΩ < R ≤ 27MΩ
RTV20 (2010)	3/4 W	500V	1000V	±100	10Ω ≤ R ≤ 1MΩ	10Ω ≤ R ≤ 1MΩ	10Ω ≤ R ≤ 1MΩ
				±200	-----	1Ω ≤ R < 10Ω 1MΩ < R ≤ 10MΩ	1Ω ≤ R < 10Ω 1MΩ < R ≤ 10MΩ
RTV25 (2512)	1W	500V	1000V	±100	10Ω ≤ R ≤ 1MΩ	10Ω ≤ R ≤ 1MΩ	10Ω ≤ R ≤ 1MΩ
				±200	-----	1Ω ≤ R < 10Ω 1MΩ < R ≤ 10MΩ	1Ω ≤ R < 10Ω 1MΩ < R ≤ 10MΩ
Operating Temperature Range				-55°C ~ +155°C			

Written 朱翠平	Checked 汪晓伟	Approved 	QA Signing 全红霞	Remark IT'S NOT UNDER CONTROL FOR PDF FILE PLS NOTE THE VERSION STATED.. Do not copy without permission	Issue Dep. DATA Center. Series No. 60
-----------------------	-----------------------	---------------------	--------------------------	---	--

RTV Series Thick Film Chip Resistors Product Specification

Document No.	IE-SP-038
Released Date	2021/07/09
Page No.	2

3.1 Power Derating Curve:

Operating Temperature Range : - 55~155 °C

For resistors operated in ambient temperatures above 70°C, power rating shall be derated in accordance with figure below .

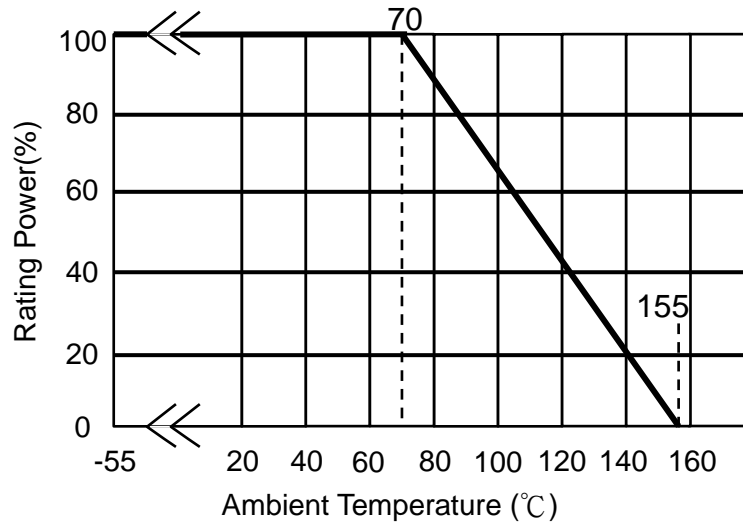

3.2 Voltage Rating:

Rated Voltage: The resistor shall have a DC continuous working voltage or a rms. AC continuous working voltage at commercial-line frequency and wave form corresponding to the power rating, as determined from the following:

$$E = \sqrt{R \times P}$$

E= Rated voltage (v)
P= Power rating (w)
R= Nominal resistance(Ω)

4 Dimensions:

Unit:mm

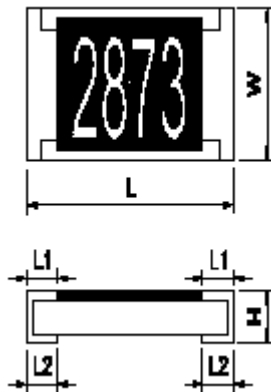

Dimension		L	W	H	L1	L2
Type	Size Code					
RTV03	0603	1.60±0.10	0.80±0.10	0.45±0.10	0.30±0.15	0.30±0.15
RTV05	0805	2.00±0.10	1.25±0.10	0.50±0.10	0.35±0.20	0.35±0.15
RTV06	1206	3.05±0.10	1.55±0.10	0.50±0.10	0.45±0.20	0.35±0.15
RTV12	1210	3.05±0.10	2.55±0.10	0.55±0.10	0.50±0.20	0.50±0.20
RTV20	2010	5.00±0.20	2.50±0.20	0.55±0.10	0.60±0.20	0.60±0.20
RTV25	2512	6.30±0.20	3.20±0.20	0.55±0.10	0.60±0.20	0.69±0.20

Remark

IT'S NOT UNDER CONTROL FOR PDF FILE
PLS NOTE THE VERSION STATED..

Issue Dep. **DATA Center.**

Do not copy without permission

Series No. **60**

RTV Series Thick Film Chip Resistors Product Specification

Document No.	IE-SP-038
Released Date	2021/07/09
Page No.	3

5 Structure Graph:

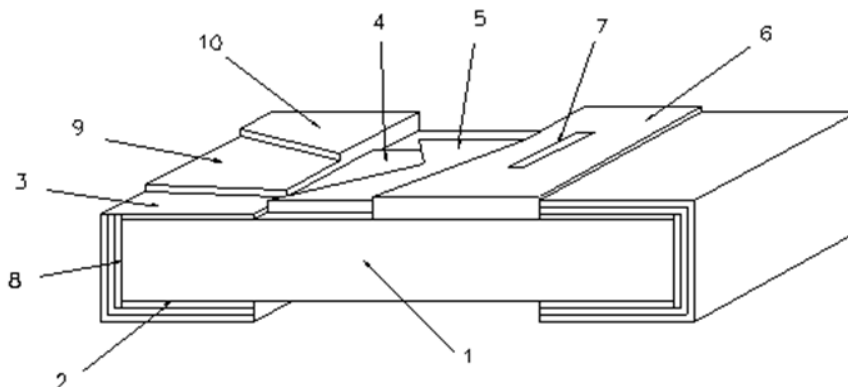

1	Ceramic substrate	6	2nd Protective coating
2	Bottom inner electrode	7	Marking
3	Top inner electrode	8	Terminal inner electrode
4	Resistive layer	9	Ni plating
5	1st Protective coating	10	Sn plating

Remark

IT'S NOT UNDER CONTROL FOR PDF FILE
PLS NOTE THE VERSION STATED..

Do not copy without permission

Issue Dep. **DATA Center.**

Series No. **60**

RTV Series Thick Film Chip Resistors Product Specification

Document No.	IE-SP-038
Released Date	2021/07/09
Page No.	4

6 Reliability Test:

6.1 Electrical Performance Test

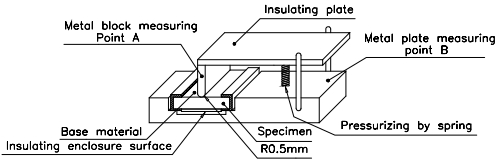
Item	Conditions	Specifications
Temperature Coefficient of Resistance	$TCR \text{ (ppm/}^\circ\text{C)} = \frac{(R2 - R1)}{R1 (T2 - T1)} \times 10^6$ R1: Resistance at room temperature R2: Resistance at -55°C or +125°C T1: Room temperature T2: Temperature -55°C or +125°C Refer to JIS-C5201-1 4.8	Refer to item 3. general specifications
Short Time Overload	Applied 2.5 times rated voltage for 5 seconds and release the load for about 30 minutes, then measure its resistance variance rate. (Rated voltage refer to item 3. general specifications) Refer to JIS-C5201-1 4.13	0.5%、1%: $\Delta R\% = \pm 1.0\%$ 5% : $\Delta R\% = \pm 2.0\%$
Insulation Resistance	Put the resistor in the fixture, add 100 VDC in +, - terminal for 60 sec then measured the insulation resistance between electrodes and insulating enclosure or between electrodes and base material. Refer to JIS-C5201-1 4.6 	$\geq 10^9 \Omega$
Dielectric Withstand Voltage	Put the resistor in the fixture, add VAC (see spec. below) in +, - terminal for. RTV05、06、20、25 apply 500 VAC 1 minute. RTV03 apply 300 VAC 1 minute. Refer to JIS-C5201-1 4.7	No short or burned on the appearance.

Remark

IT'S NOT UNDER CONTROL FOR PDF FILE
PLS NOTE THE VERSION STATED..

Issue Dep. **DATA Center.**

Do not copy without permission

Series No. **60**

RTV Series Thick Film Chip Resistors Product Specification

Document No.	IE-SP-038
Released Date	2021/07/09
Page No.	5

6.2 Mechanical Performance Test

Item	Conditions	Specifications Resistors
Terminal Strength	Test1: The resistor mounted on the board applied 5N pushing force on the sample rear for 10 sec. Test2: The resistor mounted on the board slowly add force on the sample rear until the sample termination is breakdown. Refer to JIS-C5201-1 4.16	Test 1: No evidence of mechanical damage. Test 2: $F \geq 5N$
Resistance to Solvent	The tested resistor be immersed into isopropyl alcohol of 20~25°C for 5 minutes, then the resistor is left in the room for 48 hrs., and measured its resistance variance rate. Refer to JIS-C5201-1 4.29	$\Delta R\% = \pm 0.5\%$
Solderability	Preconditioning: Put the tested resistor in the apparatus of PCT, at a temperature of 105°C, humidity of 100% RH, and pressure of 1.22×10^5 Pa for a duration of 4 hours. Then after left the tested resistor in room temperature for 2 hours or more. Test method: The resistor be immersed into solder pot in temperature $235 \pm 5^\circ C$ for 2 sec, then the resistor is left as placed under microscope to observed its solder area. Refer to JIS-C5201-1 4.17	Solder coverage over 95%
Resistance to Soldering Heat	◎Test method 1 (solder pot test): The tested resistor be immersed into molten solder of $260 + 5 / - 0^\circ C$ for 10 seconds. Then the resistor is left in the room for 1 hour. ◎Test method 2 (solder pot test): The tested resistor be immersed into molten solder of $260 + 5 / - 0^\circ C$ for 30 seconds. Then the resistor is left as placed under microscope to observe its solder area. ◎Test method 3 (Electric iron test): Preheating temperature : $350 \pm 10^\circ C$ Electric iron preheating time : $3 + 1 / - 0$ sec Preheating the electric iron on electrode termination, as after that step placed the iron over 60 min. and measured its resistance variance rate. Refer to JIS-C5201-1 4.18	Test item 1: (1). Variance rate on resistance $\Delta R\% = \pm 1.0\%$ Test item 2: (1). Solder coverage over 95%. (2). The underlying material (such as ceramic) shall not be visible at the crest corner area of the electrode. Test item 3: (1). Variance rate on resistance $\Delta R\% = \pm 1.0\%$

Remark	<div style="border: 1px solid black; padding: 5px; display: inline-block;"> IT'S NOT UNDER CONTROL FOR PDF FILE PLS NOTE THE VERSION STATED.. </div>	Issue Dep. DATA Center.
	Do not copy without permission	Series No. 60

RTV Series Thick Film Chip Resistors Product Specification

Document No.	IE-SP-038
Released Date	2021/07/09
Page No.	6

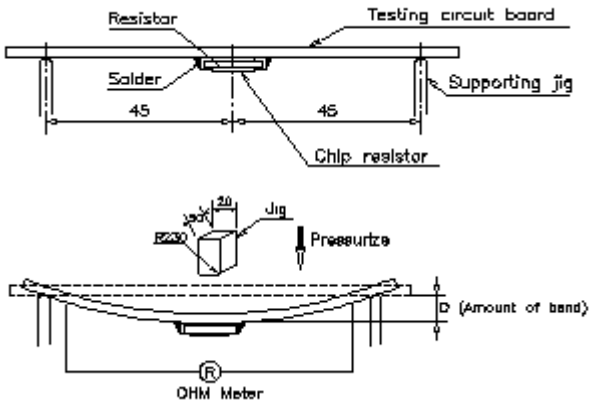
Item	Conditions	Specifications
Joint Strength of Solder	<p>◎Bending Strength: Solder tested resistor on to PC board. Add force in the middle down, and under load measured its resistance variance rate. D:RTV03、05=5mm RTV06、12=3mm RTV20、25=2mm</p>  <p>Refer to JIS-C5201-1 4.33</p>	<p>Resistors</p> <p>$\Delta R\% = \pm 1.0\%$</p>

Remark

IT'S NOT UNDER CONTROL FOR PDF FILE
PLS NOTE THE VERSION STATED..

Do not copy without permission

Issue Dep. **DATA Center.**

Series No. **60**

RTV Series Thick Film Chip Resistors Product Specification

Document No.	IE-SP-038
Released Date	2021/07/09
Page No.	7

6.3 Environmental Test

Item	Conditions	Specifications Resistors								
Resistance to Dry Heat	Put tested resistor in chamber under temperature $155\pm 5^{\circ}\text{C}$ for 1000 +48/-0 hours. Then leaving the tested resistor in room temperature for 60 minutes, and measure its resistance variance rate. Refer to JIS-C5201-1 4.25	0.5%、1%: $\Delta R\%=\pm 1.0\%$ 5%: $\Delta R\%=\pm 2.0\%$								
Thermal Shock	Put the tested resistor in the chamber under the Thermal Shock which shown in the following table shall be repeated 300 times consecutively. Then leaving the tested resistor in the room temperature for 1 hours, and measure its resistance variance rate. <table border="1" style="margin-left: auto; margin-right: auto; border-collapse: collapse;"> <thead> <tr> <th colspan="2" style="text-align: center;">Testing Condition</th> </tr> </thead> <tbody> <tr> <td style="text-align: center;">Lowest Temperature</td> <td style="text-align: center;">$-55\pm 5^{\circ}\text{C}$</td> </tr> <tr> <td style="text-align: center;">Highest Temperature</td> <td style="text-align: center;">$125\pm 5^{\circ}\text{C}$</td> </tr> <tr> <td style="text-align: center;">Temperature-retaining time</td> <td style="text-align: center;">15 minutes each</td> </tr> </tbody> </table> Refer to MIL-STD 202 Method 107	Testing Condition		Lowest Temperature	$-55\pm 5^{\circ}\text{C}$	Highest Temperature	$125\pm 5^{\circ}\text{C}$	Temperature-retaining time	15 minutes each	0.5%、1%: $\Delta R\%=\pm 0.5\%$ 5%: $\Delta R\%=\pm 1.0\%$
Testing Condition										
Lowest Temperature	$-55\pm 5^{\circ}\text{C}$									
Highest Temperature	$125\pm 5^{\circ}\text{C}$									
Temperature-retaining time	15 minutes each									
Loading Life in Moisture	Put the tested resistor in the chamber under temperature $40\pm 2^{\circ}\text{C}$, relative humidity 90~95% and load the rated voltage for 90 minutes on, 30 minutes off, total 1000 hours. Then leaving the tested resistor in room temperature for 60 minutes, and measure its resistance variance rate. Refer to JIS-C5201-1 4.24	0.5%、1%: $\Delta R\%=\pm 2.0\%$ 5%: $\Delta R\%=\pm 3.0\%$								
Load Life	Put the tested resistor in chamber under temperature $70\pm 2^{\circ}\text{C}$ and load the rated voltage for 90 minutes on, 30 minutes off, total 1000 hours. Then leaving the tested resistor in room temperature for 60 minutes, and measure its resistance variance rate. Refer to JIS-C5201-1 4.25	0.5%、1%: $\Delta R\%=\pm 2.0\%$ 5%: $\Delta R\%=\pm 3.0\%$								

Remark	<div style="border: 1px solid black; padding: 5px; display: inline-block;"> IT'S NOT UNDER CONTROL FOR PDF FILE PLS NOTE THE VERSION STATED.. </div>	Issue Dep. DATA Center. Series No. 60
	Do not copy without permission	

RTV Series Thick Film Chip Resistors Product Specification

Document No.	IE-SP-038
Released Date	2021/07/09
Page No.	8

7 Measurement Point:

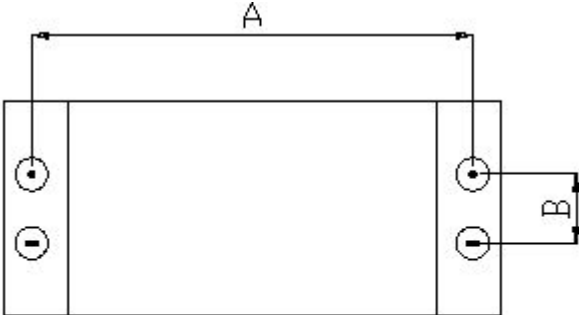
Bottom electrode	Unit : mm		
 <p style="text-align: center;"> ⊙ Current Terminal ⊖ Voltage Terminal </p>	DIM	A	B
	TYPE		
	RTV03	1.35±0.05	0.35±0.05
	RTV05	1.80±0.05	0.35±0.05
	RTV06	2.90±0.05	0.35±0.05
	RTV12	2.90±0.05	0.35±0.05
	RTV20	4.50±0.05	1.15±0.05
	RTV25	5.90±0.05	1.60±0.05

8 Plating Thickness:

8.1 Ni: $\geq 2\mu\text{m}$

8.2 Sn(Tin): $\geq 3\mu\text{m}$

8.3 Sn(Tin): Matte Sn

Remark

IT'S NOT UNDER CONTROL FOR PDF FILE
PLS NOTE THE VERSION STATED..

Issue Dep. DATA Center.

Do not copy without permission

Series No. **60**

RTV Series Thick Film Chip Resistors Product Specification

Document No.

IE-SP-038

Released Date

2021/07/09

Page No.

9

9 Technical application notes: (This is for recommendation, please customer perform adjustment according to actual application)

9.1 Recommend Soldering Method:

9.1.1 Lead Free IR Reflow Soldering Profile (MEET J-STD-020D)

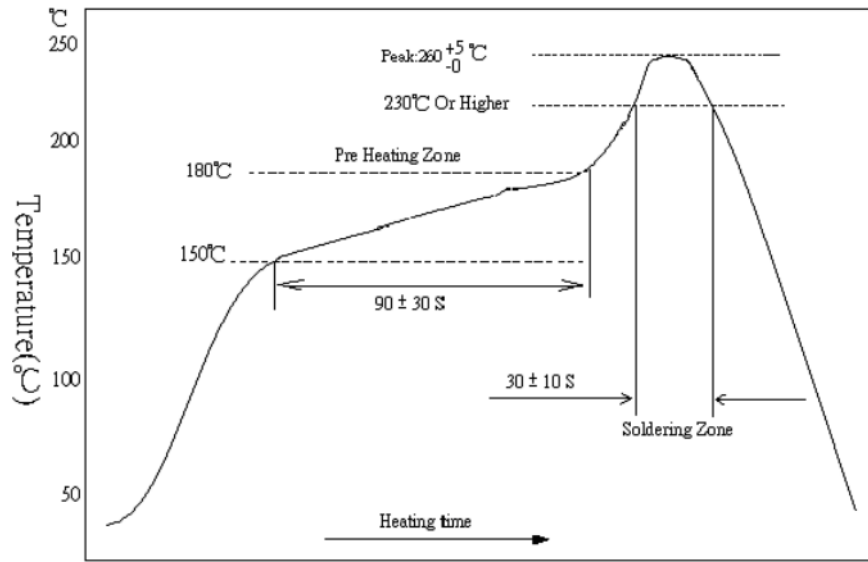

Remark: The peak temperature of soldering heat is 260^{+5}_{-0} °C for 10 seconds

9.1.2 Lead Free Double-Wave Soldering Profile.(This applies to 0603 size inclusive above products)

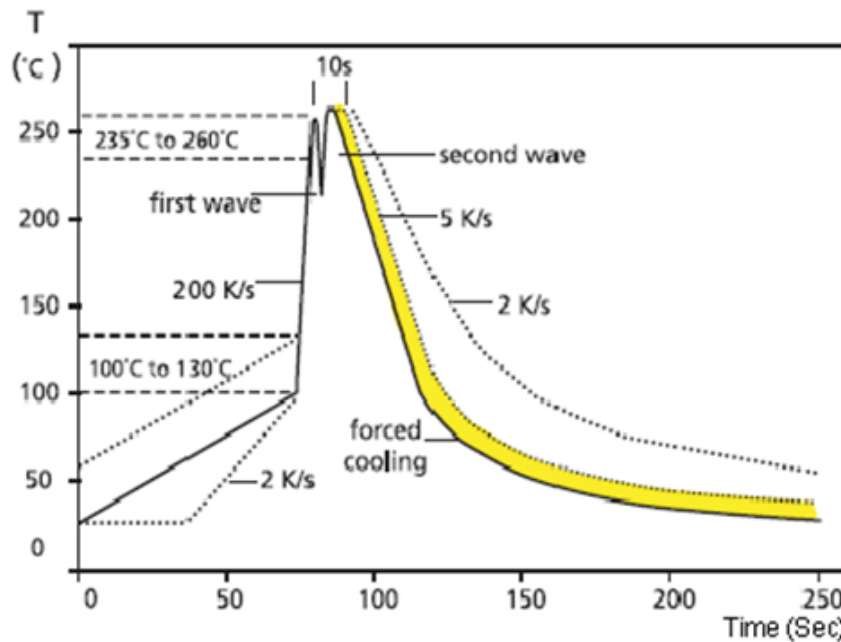

9.1.3 Soldering Iron: temperature $350^{\circ}\text{C} \pm 10^{\circ}\text{C}$, dwell time shall be less than 3 sec.

Remark

IT'S NOT UNDER CONTROL FOR PDF FILE
PLS NOTE THE VERSION STATED..

Issue Dep. DATA Center.

Do not copy without permission

Series No. **60**

RTV Series Thick Film Chip Resistors Product Specification

Document No.	IE-SP-038
Released Date	2021/07/09
Page No.	10

9.2 Recommend Land Pattern Design (For Reflow Soldering):

When a component is soldered, the resistance after soldering changes slightly depending on the size of the soldering area and the amount of soldering. When designing a circuit, it is necessary to consider the effect of a decrease or increase in its resistance.

Unit:mm

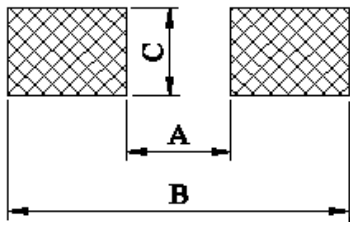

TYPE \ DIM	A	B	C
RTV03	0.8	2.1	0.9
RTV05	1.2	3.0	1.3
RTV06	2.2	4.2	1.6
RTV12	2.2	4.2	2.8
RTV20	3.5	6.1	2.8
RTV25	3.8	8.0	3.5

9.3 Environment Precautions:

This specification product is for general electronic use, RALEC will not be responsible for any damage, cost or loss caused by using this specification product in any special environment. If other applications need to confirm with RALEC.

If consumer intends to use our Company product in special environment or condition (including but not limited to those mentioned below), then will need to make individual recognition of product features and reliability accordingly.

- Used in high temperature and humidity environment
- Exposed to sea breeze or other corrosive gas, such as Cl₂、H₂S、NH₃、SO₂ and NO₂.
- Used in non-verified liquids including water, oil, chemical and organic solvents.
- Using non-verified resin or other coating material to seal or coat our Company product.
- After soldering, it is necessary to use water-soluble detergents to clean residual solder fluxes, even though no-clean fluxes are recommended.

9.4 Momentary Overload Precautions:

The product might be out of function when momentary overloaded. Please make sure to avoid momentary overloading while using and preserving.

Remark

IT'S NOT UNDER CONTROL FOR PDF FILE
PLS NOTE THE VERSION STATED..

Issue Dep. DATA Center.

Do not copy without permission

Series No. **60**

RTV Series Thick Film Chip Resistors Product Specification

Document No.	IE-SP-038
Released Date	2021/07/09
Page No.	11



9.5 Operation and Processing Precautions:

- (a) Avoid damage to the edge of resistor and protective layer caused by mechanical stress.
- (b) Handle with care when printing circuit board (PCB) is divided or fixed on support body, because bending of printing circuit board (PCB) mounting will make mechanical stress for resistors.
- (c) Make sure the power rating is under the limit when using the resistor. When power rating is over the limit, the resistor will be overloaded. There might be machinery damage due to the climbing temperature.
- (d) If the resistor will be exposed under massive impact load (shock wave) in a short period of time, the working environment must be set up well before use.
- (e) Please make evaluation and confirmation when the product is well used in your company and have a through consideration of it's fail-safe design to ensure the system safety.

10 Storage and transportation requirement:

- 10.1 The temperature condition must be controlled at $25\pm 5^{\circ}\text{C}$, the R.H. must be controlled at $60\pm 15\%$. The stock can maintain quality level in two years.
- 10.2 Please avoid the mentioned harsh environment below when storing to ensure product performance and its' weldability. Places exposed to sea breeze or other corrosive gas, such as Cl_2 、 H_2S 、 NH_3 、 SO_2 and NO_2 .
- 10.3 When the product is moved and stored, please ensure the correct orientation of the box. Do not drop or squeeze the box. Otherwise, the electrode or the body of the product may be damaged.

11 The carton packaged for electronic-information products is made by the symbol as follows: (For china)

	
Marking for control of pollution cause by electronic-information products	Marking for package recovery

Remark	<div style="border: 1px solid black; padding: 5px; display: inline-block;"> IT'S NOT UNDER CONTROL FOR PDF FILE PLS NOTE THE VERSION STATED.. </div>	Issue Dep. DATA Center.
	Do not copy without permission	Series No. 60

RTV Series Thick Film Chip Resistors Product Specification

Document No.	IE-SP-038
Released Date	2021/07/09
Page No.	12

Legal disclaimer

RALEC, its distributors and agents (collectively, "RALEC"), hereby disclaims any and all liabilities for any errors, inaccuracies or incompleteness contained in any product related information, including but not limited to product specifications, datasheets, pictures and/or graphics. RALEC may make changes, modifications and/or improvements to product related information at any time and without notice.

RALEC makes no representation, warranty, and/or guarantee about the fitness of its products for any particular purpose or the continuing production of any of its products. To the maximum extent permitted by law, RALEC disclaims (i) any and all liability arising out of the application or use of any RALEC product, (ii) any and all liability, including without limitation special, consequential or incidental damages, and (iii) any and all implied warranties, including warranties of fitness for a particular purpose, non-infringement and merchantability.

RALEC defined this product is for general electrical use , not design for any application for automotive electrical ,life-saving or life support equipment, or any application which may inflict casualties if RALEC product failure occurred. When consumer is using or selling products of RALEC without having discussion with the sales representatives and specifically stated the applicability mentioned above in a written form, then the client need to take a full responsibility and agree to protect RALEC from punishment and damage.

Information provided here is intended to indicate product specifications only. RALEC reserves all the rights for revising this content without further notification, as long as products are unchanged. Any product change will be announced by ECN.

Remark

IT'S NOT UNDER CONTROL FOR PDF FILE
PLS NOTE THE VERSION STATED..

Do not copy without permission

Issue Dep. **DATA Center.**

Series No. **60**