

# RTT Series Low-Resistance Thick Film Chip Resistors Product Specification

Document No.	IE-SP-123
Released Date	2021/07/08
Page No.	1

## 1 Scope:

- 1.1 This specification is applicable to lead free and halogen free of RoHS directive for RTT series Low-Resistance thick film chip resistors.
- 1.2 The product is for general electronic purpose.

## 2 Explanation Of Part Numbers:

(EX)

Type	Size	Nominal Resistance		Resistance Tolerance	Packaging(Refer to IE-SP-055)
RTT series Low-Resistance Thick Film Chip Resistors	01(0201) 02(0402) 03(0603) 05(0805) 06(1206) 12(1210) 18(1812) 20(2010) 25(2512)	3-Digit	5% $0.1\Omega \leq R < 1\Omega$ EX. $0.1\Omega = R10$	F=± 1% J=± 5%	Q1 : 1 mm Pitch Carrier Tape 20000 pcs QE : 1 mm Pitch Carrier Tape 150000 pcs TH : 2 mm Pitch Carrier Tape 10000 pcs H0 : 2 mm Pitch Carrier Tape 15000 pcs H1 : 2 mm Pitch Carrier Tape 20000 pcs H2 : 2 mm Pitch Carrier Tape 20000 pcs H3 : 2 mm Pitch Carrier Tape 30000 pcs H4 : 2 mm Pitch Carrier Tape 40000 pcs H5 : 2 mm Pitch Carrier Tape 50000 pcs H6 : 2 mm Pitch Carrier Tape 60000 pcs TP : 4 mm Pitch Carrier Tape 5000 pcs P2 : 4 mm Pitch Carrier Tape 10000 pcs P3 : 4 mm Pitch Carrier Tape 15000 pcs P4 : 4 mm Pitch Carrier Tape 20000 pcs TE : 4 mm Pitch Carrier Tape 4000 pcs E6 : 8 mm Pitch Carrier Tape 2000 pcs BA : Bulk Case
		4-Digit	5% $R < 0.1\Omega$ EX. $0.036\Omega = R036$		
			1% EX. $0.1\Omega = R100$		

IE			QA		Remark	Issue Dep. DATA Center.
Written	Checked	Approved	Signing			
朱翠平	汪晓伟	马建	仝红霞		IT'S NOT UNDER CONTROL FOR PDF FILE PLS NOTE THE VERSION STATED..	Series No. <b>60</b>
					Do not copy without permission	

# RTT Series Low-Resistance Thick Film Chip Resistors Product Specification

Document No.	IE-SP-123
Released Date	2021/07/08
Page No.	2

## 3 General Specifications

Type	Rated Power at 70°C	Max. Rated Current	Max. Overload Current	T.C.R ( ppm / °C )	Resistance Range
					F(±1%) · J(±5%) E-24 · E-96
RTT01 (0201)	$\frac{1}{20}$ W	0.70A	1.76A	±700	100mΩ ≤ R < 200mΩ
				±500	200mΩ ≤ R < 400mΩ
				±300	400mΩ ≤ R < 600mΩ
				±250	600mΩ ≤ R < 1000mΩ
RTT02 (0402)	$\frac{1}{16}$ W	1.77A	4.42A	±1500	20 mΩ ≤ R < 37 mΩ
				±1200	37 mΩ ≤ R < 60 mΩ
				±600	60 mΩ ≤ R < 200 mΩ
				±300	200 mΩ ≤ R < 400 mΩ
				±250	400 mΩ ≤ R < 600 mΩ
RTT03 (0603)	$\frac{1}{10}$ W	3.16A	7.91A	±1500	10 mΩ ≤ R < 37 mΩ
				±1200	37 mΩ ≤ R < 60 mΩ
				±600	60 mΩ ≤ R < 100 mΩ
				±300	100 mΩ ≤ R < 200 mΩ
				±600	200 mΩ ≤ R < 500 mΩ
RTT05 (0805)	$\frac{1}{8}$ W	3.53A	8.82A	±400	500 mΩ ≤ R < 1000 mΩ
				±1500	10 mΩ ≤ R < 19 mΩ
				±1200	19 mΩ ≤ R < 33 mΩ
				±800	33 mΩ ≤ R < 50 mΩ
				±600	50 mΩ ≤ R < 100 mΩ
RTT06 (1206)	$\frac{1}{3}$ W	5.77A	14.42A	±200	100 mΩ ≤ R < 1000 mΩ
				±1500	10 mΩ ≤ R < 19 mΩ
				±1200	19 mΩ ≤ R < 25 mΩ
				±1000	25 mΩ ≤ R < 50 mΩ
				±600	50 mΩ ≤ R < 100 mΩ
RTT12 (1210)	$\frac{1}{2}$ W	7.07A	17.67A	±200	100 mΩ ≤ R < 1000 mΩ
				±1500	10 mΩ ≤ R < 19 mΩ
				±1000	19 mΩ ≤ R < 25 mΩ
				±700	25 mΩ ≤ R < 50 mΩ
				±400	50 mΩ ≤ R < 100 mΩ
RTT18 (1812)	$\frac{3}{4}$ W	8.66A	21.65A	±200	100 mΩ ≤ R < 1000 mΩ
				±1500	10 mΩ ≤ R < 19 mΩ
				±1200	19 mΩ ≤ R < 25 mΩ
				±900	25 mΩ ≤ R < 50 mΩ
				±500	50 mΩ ≤ R < 100 mΩ
RTT20 (2010)	$\frac{3}{4}$ W	8.66A	21.65A	±200	100 mΩ ≤ R < 1000 mΩ
				±1500	10 mΩ ≤ R < 19 mΩ
				±1200	19 mΩ ≤ R < 25 mΩ
				±900	25 mΩ ≤ R < 50 mΩ
				±500	50 mΩ ≤ R < 100 mΩ
RTT25 (2512)	1 W	10A	25A	±200	100 mΩ ≤ R < 1000 mΩ
				±1500	10 mΩ ≤ R < 19 mΩ
				±1200	19 mΩ ≤ R < 25 mΩ
				±900	25 mΩ ≤ R < 50 mΩ
				±500	50 mΩ ≤ R < 100 mΩ
Operating Temperature Range				-55°C ~ +155°C (0201: -55°C ~ +125°C)	

Remark

IT'S NOT UNDER CONTROL FOR PDF FILE  
PLS NOTE THE VERSION STATED..

Issue Dep. DATA Center.

Do not copy without permission

Series No. **60**

# RTT Series Low-Resistance Thick Film Chip Resistors Product Specification

Document No.	IE-SP-123
Released Date	2021/07/08
Page No.	3

## 3.1 Power Derating Curve:

Type	RTT01 (0201)	Other
Operating Temperature Range	-55°C ~ +125°C	-55°C ~ +155°C
Explain	For resistors operated in ambient temperatures above 70°C, power rating shall be derated in accordance with figure below.	For resistors operated in ambient temperatures above 70°C, power rating shall be derated in accordance with figure below.
Figure		

## 3.2 Current Rating

Rated Current: The resistor shall have a DC continuous working current or a rms. AC continuous working current at commercial-line frequency and wave form corresponding to the power rating, as determined from the following:

$$I = \sqrt{P/R}$$

I= Rated current (A)  
 P= Power rating (w)  
 R= Nominal resistance(Ω)

## 4 Dimensions:

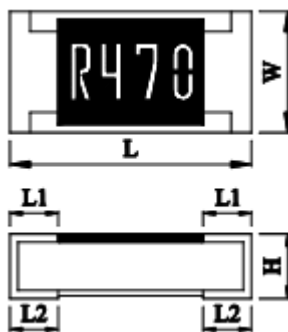

Dimension		Unit:mm				
Type	Size Code	L	W	H	L1	L2
RTT01	0201	0.60±0.03	0.30±0.03	0.23±0.03	0.15±0.05	0.15±0.05
RTT02	0402	1.00±0.10	0.50±0.05	0.30±0.10	0.25±0.10	0.20±0.15
RTT03	0603	1.60±0.10	0.80±0.10	0.45±0.10	0.25±0.15	0.35±0.15
RTT05	0805	2.00±0.10	1.25±0.10	0.50±0.10	0.35±0.20	0.35±0.20
RTT06	1206	3.05±0.10	1.55±0.10	0.50±0.10	0.45±0.20	0.55±0.25
RTT12	1210	3.05±0.10	2.55±0.10	0.55±0.10	0.50±0.20	0.50±0.20
RTT18	1812	4.40±0.20	3.15±0.20	0.47±0.20	0.60±0.20	0.60±0.20
RTT20	2010	5.00±0.20	2.50±0.20	0.60±0.10	0.65±0.20	0.65±0.20
RTT25	2512	6.30±0.20	3.20±0.20	0.60±0.10	0.65±0.20	0.65±0.20

Remark

IT'S NOT UNDER CONTROL FOR PDF FILE  
PLS NOTE THE VERSION STATED..

Issue Dep. DATA Center.

Do not copy without permission

Series No. **60**

# RTT Series Low-Resistance Thick Film Chip Resistors Product Specification

Document No.

IE-SP-123

Released Date

2021/07/08

Page No.

4

## 5 Structure Graph:

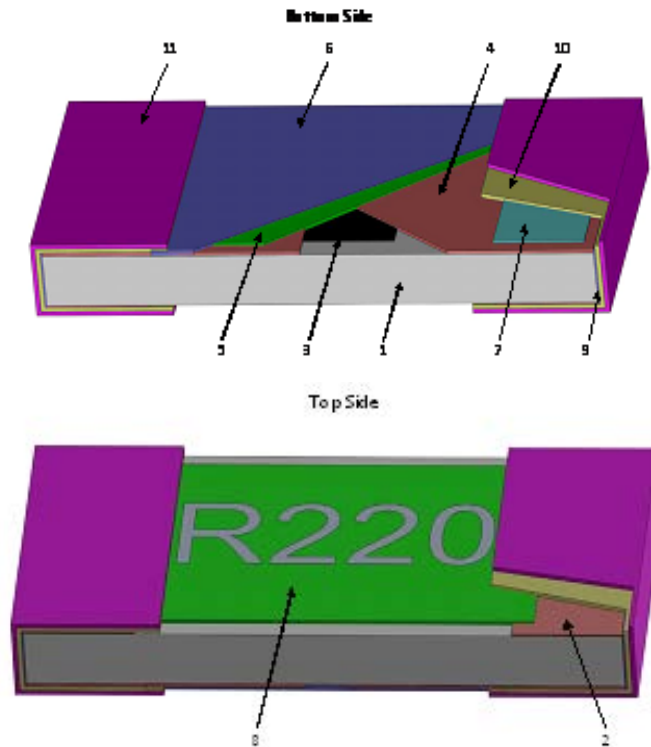

1	Ceramic substrate	7	2 <sup>nd</sup> Bottom inner electrode
2	Top inner electrode	8	G2 layer+Marking
3	Resistive layer	9	Terminal inner electrode
4	1 <sup>st</sup> Bottom inner electrode	10	Ni plating
5	1st Protective coating	11	Sn plating
6	2nd Protective coating		

Remark

IT'S NOT UNDER CONTROL FOR PDF FILE  
PLS NOTE THE VERSION STATED..

Issue Dep. DATA Center.

Do not copy without permission

Series No. **60**

# RTT Series Low-Resistance Thick Film Chip Resistors Product Specification

Document No.	IE-SP-123
Released Date	2021/07/08
Page No.	5

## 6 Reliability Test:

### 6.1 Electrical Performance Test

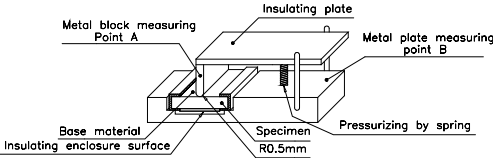
Item	Conditions	Specifications
		Resistors
Temperature Coefficient of Resistance	$TCR \text{ (ppm / } ^\circ\text{C)} = \frac{(R2 - R1)}{R1 (T2 - T1)} \times 10^6$ R1: Resistance at room temperature R2: Resistance at -55°C or +125°C T1: Room temperature T2: Temperature -55°C or +125°C  Refer to JIS-C5201-1 4.8	Refer to item 3. general specifications
Short Time Overload	Applied 2.5 times rated current for 5 seconds and release the load for about 30 minutes, then measure its resistance variance rate. (Rated current refer to item 3. general specifications)  Refer to JIS-C5201-1 4.13	$\Delta R = \pm 2.0\%$
Insulation Resistance	Put the resistor in the fixture, add 100 VDC in +, - terminal for 60 sec then measured the insulation resistance between electrodes and insulating enclosure or between electrodes and base material. Refer to JIS-C5201-1 4.6  	$\geq 10^9 \Omega$
Dielectric Withstand Voltage	Put the resistor in the fixture, add VAC (see SPEC below) in +, - terminal for. RTT05、06、12、18、20、25 apply 500 VAC 1 minute. RTT01、02、03 apply 300 VAC 1 minute.  Refer to JIS-C5201-1 4.7	No short or burned on the appearance.
Intermittent Overload	Put the tested resistor in chamber under temperature $25 \pm 2^\circ\text{C}$ and load 2.5 times rated DC current for 1 sec on, 25 sec off, $10000^{+400}_0$ test cycles, then it be left at no-load for 1 hour, then measure its resistance variance rate.  Refer to JIS-C5201-1 4.13	$\Delta R = \pm 5.0\%$

Remark

IT'S NOT UNDER CONTROL FOR PDF FILE  
PLS NOTE THE VERSION STATED..

Issue Dep. DATA Center.

Do not copy without permission

Series No. **60**

# RTT Series Low-Resistance Thick Film Chip Resistors Product Specification

<b>Document No.</b>	<b>IE-SP-123</b>
<b>Released Date</b>	<b>2021/07/08</b>
<b>Page No.</b>	<b>6</b>

## 6.2 Mechanical Performance Test

Item	Conditions	Specifications
		Resistors
Terminal Strength	Test 1 : The resistor mounted on the board applied 5N pushing force on the sample rear for 10 sec. Test 2 : The resistor mounted on the board slowly add force on the sample rear until the sample termination is breakdown.  Refer to JIS-C5201-1 4.16	Test 1 : No evidence of mechanical damage. Test 2 : $F \geq 5N$
Resistance to Solvent	The tested resistor be immersed into isopropyl alcohol of 20~25°C for 5 minutes, then the resistor is left in the room for 48 hrs, and measured its resistance variance rate.  Refer to JIS-C5201-1 4.29	$\Delta R = \pm 2.0\%$
Solderability	Preconditioning Put the tested resistor in the apparatus of PCT, at a temperature of 105°C, humidity of 100% RH, and pressure of 1.22x105 Pa for a duration of 4 hours. Then after left the tested resistor in room temperature for 2 hours or more. Test method: The resistor be immersed into solder pot in temperature 235±5°C for 2 sec, then the resistor is left as placed under microscope to observed its solder area.  Refer to JIS-C5201-1 4.17	Solder coverage over 95%
Resistance to Soldering Heat	◎Test method 1 (Solder pot test): The tested resistor be immersed into molten solder of 260+5/-0°C for 10 seconds. Then the resistor is left in the room for 1 hour.  ◎Test method 2 (Solder pot test): The tested resistor be immersed into molten solder of 260+5/-0°C for 30 seconds. Then the resistor is left as placed under microscope to observe its solder area.  ◎Test method 3 (Electric iron test): Preheating temperature : 350±10°C Electric iron preheating time : 3+1/-0 sec Preheating the electric iron on electrode termination, as after that step placed the iron over 60 min. and measured its resistance variance rate.  Refer to JIS-C5201-1 4.18	Test item 1: $\Delta R = \pm 2.0\%$  Test item 2: (1). Solder coverage over 95%. (2). The underlying material (such as ceramic) shall not be visible at the crest corner area of the electrode.  Test item 3: $\Delta R = \pm 2.0\%$

Remark

IT'S NOT UNDER CONTROL FOR PDF FILE  
PLS NOTE THE VERSION STATED..

Issue Dep. **DATA Center.**

Do not copy without permission

Series No. **60**

# RTT Series Low-Resistance Thick Film Chip Resistors Product Specification

Document No.	IE-SP-123
Released Date	2021/07/08
Page No.	7

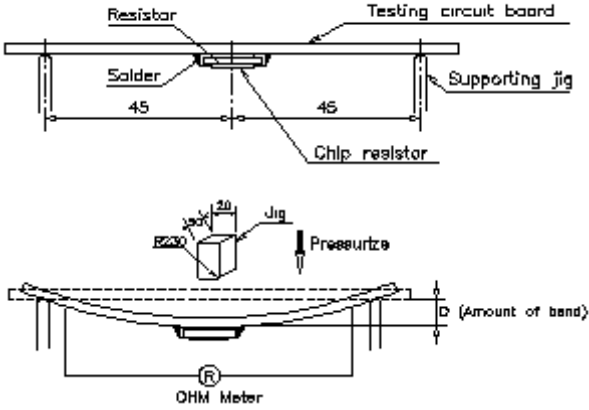
Item	Conditions	Specifications
		Resistors
Joint Strength of Solder	<p>◎Bending Strength: Solder tested resistor on to PC board add force in the middle down, and under load measured its resistance variance rate. D:RTT02・03・05=5mm RTT01・06・12=3mm RTT18・20・25=2mm</p>  <p>Refer to JIS-C5201-1 4.33</p>	$\Delta R = \pm 2.0\%$

## 6.3 Environmental Test

Item	Conditions	Specifications								
		Resistors								
Resistance to Dry Heat	<p>Put tested resistor in chamber under temperature <math>155 \pm 5^\circ\text{C}</math> for 1000 +48/-0 hours. Then leaving the tested resistor in room temperature for 60 minutes, and measure its resistance variance rate.</p> <p>Refer to JIS-C5201-1 4.25</p>	$\Delta R = \pm 2.0\%$								
Thermal Shock	<p>Put the tested resistor in the chamber under the Thermal Shock which shown in the following table shall be repeated 300 times consecutively. Then leaving the tested resistor in the room temperature for 1 hours, and measure its resistance variance rate.</p> <table border="1" data-bbox="376 1406 971 1532"> <thead> <tr> <th colspan="2">Testing Condition</th> </tr> </thead> <tbody> <tr> <td>Lowest Temperature</td> <td><math>-55 \pm 5^\circ\text{C}</math></td> </tr> <tr> <td>Highest Temperature</td> <td><math>125 \pm 5^\circ\text{C}</math></td> </tr> <tr> <td>Temperature-retaining time</td> <td>15 minutes each</td> </tr> </tbody> </table> <p>Refer to MIL-STD 202 Method 107</p>	Testing Condition		Lowest Temperature	$-55 \pm 5^\circ\text{C}$	Highest Temperature	$125 \pm 5^\circ\text{C}$	Temperature-retaining time	15 minutes each	$\Delta R = \pm 2.0\%$
Testing Condition										
Lowest Temperature	$-55 \pm 5^\circ\text{C}$									
Highest Temperature	$125 \pm 5^\circ\text{C}$									
Temperature-retaining time	15 minutes each									
Loading Life in Moisture	<p>Put the tested resistor in the chamber under temperature <math>40 \pm 2^\circ\text{C}</math>, relative humidity 90~95% and load the rated current for 90 minutes on, 30 minutes off, total 1000 hours. Then leaving the tested resistor in room temperature for 60 minutes, and measure its resistance variance rate.</p> <p>Refer to JIS-C5201-1 4.24</p>	$\Delta R = \pm 2.0\%$								
Load Life	<p>Put the tested resistor in chamber under temperature <math>70 \pm 2^\circ\text{C}</math> and load the rated current for 90 minutes on, 30 minutes off, total 1000 hours. Then leaving the tested resistor in room temperature for 60 minutes, and measure its resistance variance rate.</p> <p>Refer to JIS-C5201-1 4.25</p>	$\Delta R = \pm 2.0\%$								

Remark

IT'S NOT UNDER CONTROL FOR PDF FILE  
PLS NOTE THE VERSION STATED..

Issue Dep. DATA Center.

Do not copy without permission

Series No. **60**

# RTT Series Low-Resistance Thick Film Chip Resistors Product Specification

Document No.	IE-SP-123
Released Date	2021/07/08
Page No.	8

## 7 Measurement Point:

Bottom electrode		Unit : mm	
TYPE	DIM	A	B
		RTT01	0.44±0.05
RTT02	0.80±0.05	0.24±0.05	
RTT03	1.35±0.05	0.35±0.05	
RTT05	1.80±0.05	0.35±0.05	
RTT06	2.90±0.05	0.35±0.05	
RTT12	2.90±0.05	0.35±0.05	
RTT18	3.70±0.05	0.60±0.05	
RTT20	4.50±0.05	1.15±0.05	
RTT25	5.90±0.05	1.60±0.05	

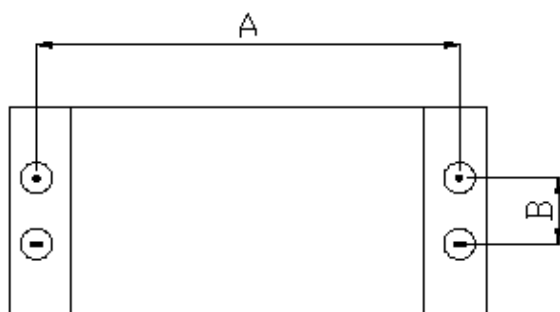

- ⊙ Current Terminal
- ⊖ Voltage Terminal

## 8 Plating Thickness:

- 8.1 Ni:  $\geq 2 \mu\text{m}$
- 8.2 Sn(Tin):  $\geq 3 \mu\text{m}$
- 8.3 Sn(Tin): Matte Sn

Remark

IT'S NOT UNDER CONTROL FOR PDF FILE  
PLS NOTE THE VERSION STATED..

Issue Dep. DATA Center.

Do not copy without permission

Series No. **60**



**9 Technical application notes: (This is for recommendation, please customer perform adjustment according to actual application)**

**9.1 Recommend Soldering Method:**

**9.1.1 Lead Free IR Reflow Soldering Profile (MEET J-STD-020D)**

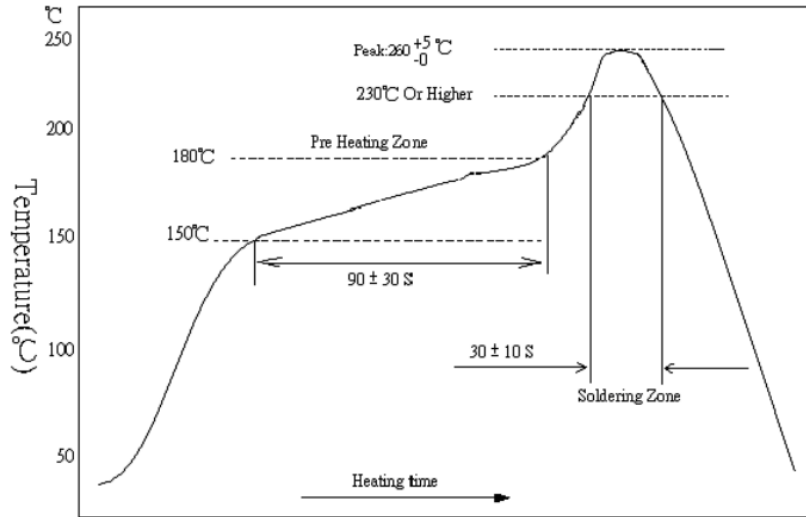

Remark: The peak temperature of soldering heat is 260 +5/-0 °C for 10 seconds

**9.1.2 Lead Free Double-Wave Soldering Profile.(This applies to 0603 size inclusive above products )**

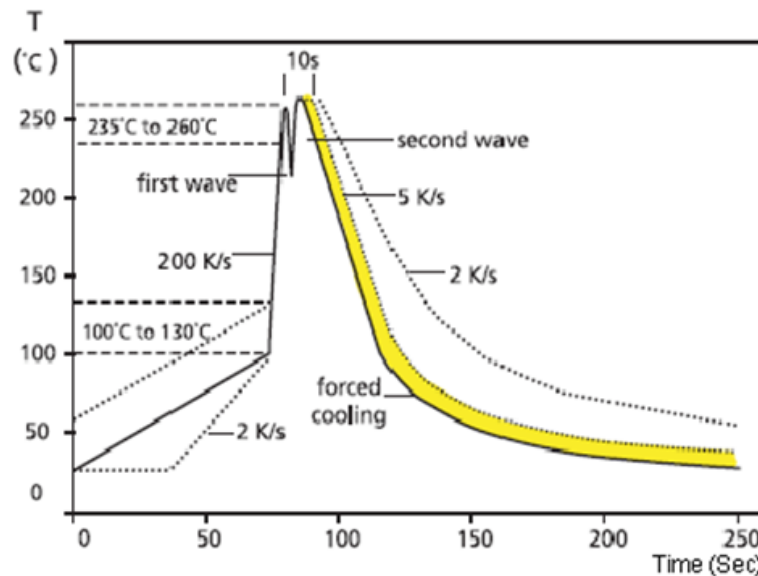

**9.1.3 Soldering Iron: temperature 350°C±10°C , dwell time shall be less than 3 sec.**

Remark

IT'S NOT UNDER CONTROL FOR PDF FILE  
PLS NOTE THE VERSION STATED..

Issue Dep. DATA Center.

Do not copy without permission

Series No. **60**

# RTT Series Low-Resistance Thick Film Chip Resistors Product Specification

Document No.	IE-SP-123
Released Date	2021/07/08
Page No.	10

## 9.2 Recommend Land Pattern Design (For Reflow Soldering)

When a component is soldered, the resistance after soldering changes slightly depending on the size of the soldering area and the amount of soldering. When designing a circuit, it is necessary to consider the effect of a decrease or increase in its resistance.

Unit:mm

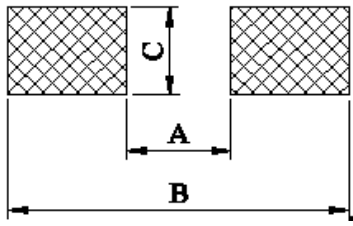

DIM TYPE	A	B	C
RTT01	0.3	1.0	0.4
RTT02	0.5	1.5	0.6
RTT03	0.8	2.1	0.9
RTT05	1.2	3.0	1.3
RTT06	2.2	4.2	1.6
RTT12	2.2	4.2	2.8
RTT18	3.1	5.9	3.0
RTT20	3.5	6.1	2.8
RTT25	3.8	8.0	3.5

## 9.3 Environment Precautions:

This specification product is for general electronic use, RALEC will not be responsible for any damage, cost or loss caused by using this specification product in any special environment. If other applications need to confirm with RALEC.

If consumer intends to use our Company product in special environment or condition (including but not limited to those mentioned below), then will need to make individual recognition of product features and reliability accordingly.

- (a) Used in high temperature and humidity environment;
- (b) Exposed to sea breeze or other corrosive gas, such as Cl<sub>2</sub>、H<sub>2</sub>S、NH<sub>3</sub>、SO<sub>2</sub> and NO<sub>2</sub>;
- (c) Used in non-verified liquids including water, oil, chemical and organic solvents;
- (d) Using non-verified resin or other coating material to seal or coat our Company product;
- (e) After soldering, it is necessary to use water-soluble detergents to clean residual solder fluxes, even though no-clean fluxes are recommended.

## 9.4 Momentary Overload Precautions:

The product might be out of function when momentary overloaded. Please make sure to avoid momentary overloading while using and preserving.

Remark

IT'S NOT UNDER CONTROL FOR PDF FILE  
PLS NOTE THE VERSION STATED..

Issue Dep. DATA Center.

Do not copy without permission

Series No. **60**

# RTT Series Low-Resistance Thick Film Chip Resistors Product Specification

Document No.	IE-SP-123
Released Date	2021/07/08
Page No.	11

## 9.5 Operation and Processing Precautions:

- (a) Avoid damage to the edge of resistor and protective layer caused by mechanical stress.
- (b) Handle with care when printing circuit board (PCB) is divided or fixed on support body, because bending of printing circuit board (PCB) mounting will make mechanical stress for resistors.
- (c) Make sure the power rating is under the limit when using the resistor. When power rating is over the limit, the resistor will be overloaded. There might be machinery damage due to the climbing temperature.
- (d) If the resistor will be exposed under massive impact load (shock wave) in a short period of time, the working environment must be set up well before use.
- (e) Please make evaluation and confirmation when the product is well used in your company and have a through consideration of it's fail-safe design to ensure the system safety.



## 10 Stock period:

10.1 The temperature condition must be controlled at  $25\pm 5^{\circ}\text{C}$ , the R.H. must be controlled at  $60\pm 15\%$ . The stock can maintain quality level in two years.

10.2 Please avoid the mentioned harsh environment below when storing to ensure product performance and its' weldability. Places exposed to sea breeze or other corrosive gas, such as  $\text{Cl}_2$ 、 $\text{H}_2\text{S}$ 、 $\text{NH}_3$ 、 $\text{SO}_2$  and  $\text{NO}_2$ .

10.3 When the product is moved and stored, please ensure the correct orientation of the box. Do not drop or squeeze the box. Otherwise, the electrode or the body of the product may be damaged.

## 11 The carton packaged for electronic-information products is made by the symbol as follows: (For china)

	
Marking for control of pollution cause by electronic-information products	Marking for package recovery

Remark

IT'S NOT UNDER CONTROL FOR PDF FILE  
PLS NOTE THE VERSION STATED..

Issue Dep. DATA Center.

Do not copy without permission

Series No. **60**

**RTT Series Low-Resistance Thick Film  
Chip Resistors Product Specification**

**Document No.**

**IE-SP-123**

**Released Date**

**2021/07/08**

**Page No.**

**12**

**Legal disclaimer**

RALEC, its distributors and agents (collectively, "RALEC"), hereby disclaims any and all liabilities for any errors, inaccuracies or incompleteness contained in any product related information, including but not limited to product specifications, datasheets, pictures and/or graphics. RALEC may make changes, modifications and/or improvements to product related information at any time and without notice.

RALEC makes no representation, warranty, and/or guarantee about the fitness of its products for any particular purpose or the continuing production of any of its products. To the maximum extent permitted by law, RALEC disclaims (i) any and all liability arising out of the application or use of any RALEC product, (ii) any and all liability, including without limitation special, consequential or incidental damages, and (iii) any and all implied warranties, including warranties of fitness for a particular purpose, non-infringement and merchantability.

RALEC defined this product is for general electrical use, not design for any application for automotive electrical ,life-saving or life support equipment, or any application which may inflict casualties if RALEC product failure occurred. When consumer is using or selling products of RALEC without having discussion with the sales representatives and specifically stated the applicability mentioned above in a written form, then the client need to take a full responsibility and agree to protect RALEC from punishment and damage.

Information provided here is intended to indicate product specifications only. RALEC reserves all the rights for revising this content without further notification, as long as products are unchanged. Any product change will be announced by ECN.

**Remark**

IT'S NOT UNDER CONTROL FOR PDF FILE  
PLS NOTE THE VERSION STATED..

Issue Dep.**DATA Center.**

Do not copy without permission

Series No. **60**