

FTT005 Thick Film Chip Resistors Product Specification

Document No.	IE-SP-157
Released Date	2019/03/06
Page No.	1

1 Scope:

- 1.1 This specification is applicable to fully lead-free and halogen-free FTT series thick film chip resistors.
- 1.2 Fully lead-free products –No RoHS exemptions.
- 1.3 The product is for general purpose.

2 Explanation of Part Numbers:

(EX)



Type	Size	Nominal Resistance		Resistance Tolerance	Packaging (Refer to IE-SP-055)
Fully Lead-free Thick Film Chip Resistors	005(01005)	5% (3-Digit)	EX. 10Ω=100 4.7Ω=4R7 JUMPER=000	F=± 1% J=± 5%	H1 : 2 mm Pitch Carrier Tape 20000 pcs
		1% (4-Digit)	EX. 10.2Ω=10R2 10KΩ=1002 JUMPER=0000		

3 General Specifications:

Type	Rated Power at 70°C	Max. Working Voltage	Max. Overload Voltage	T.C.R (ppm/°C)	Resistance Range		JUMPER (0Ω) Rated Current	JUMPER (0Ω) Resistance Value
					F(±1%) E-24、E-96	J(±5%) E-24		
FTT005 (01005)	$\frac{1}{32}$ -W	15V	30V	-200 +600	$1\Omega \leq R < 10\Omega$	$1\Omega \leq R < 10\Omega$	0.5A	50mΩ MAX
				±250	$10\Omega \leq R \leq 1M\Omega$	$10\Omega \leq R \leq 1M\Omega$		
Operating Temperature Range				-55°C ~ +125°C				

IE			QA		Remark IT'S NOT UNDER CONTROL FOR PDF FILE PLS NOTE THE VERSION STATED.. Do not copy without permission	Issue Dep. DATA Center. Series No. 60
Written	Checked	Approved	Signing			
王荷花			许国敏			

FTT005 Thick Film Chip Resistors Product Specification

Document No.	IE-SP-157
Released Date	2019/03/06
Page No.	2

3.1 Power Derating Curve:

Operating Temperature Range : - 55~125 °C

If the ambient temperature exceeds 70 degrees centigrade to 125 degrees centigrade, the power can be modified by the curve as below.

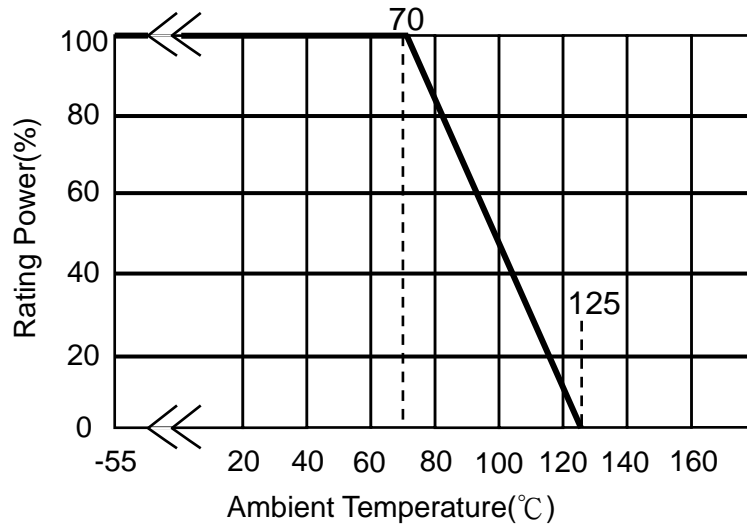

3.2 Voltage Rating

Rated Voltage: DC voltage or AC voltage (rms) based on the rated power.

The voltage can be calculated by the following formula. If the calculated value exceeds the Max. voltage specified in the Table 3.1, the Max. voltage rating is set as the voltage rating.

$$E = \sqrt{R \times P}$$

E= Voltage rating (v)
P= Power rating (w)
R= Nominal resistance(Ω)

4 Dimensions:

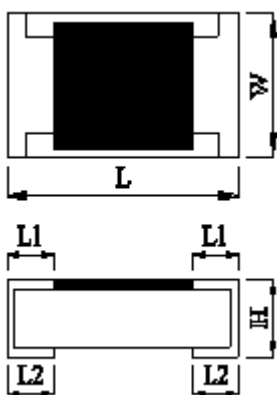

Dimension		Unit:mm				
Type	Size Code	L	W	H	L1	L2
FTT005	01005	0.40±0.02	0.20±0.02	0.13±0.02	0.10±0.03	0.10±0.03

Remark

IT'S NOT UNDER CONTROL FOR PDF FILE
PLS NOTE THE VERSION STATED..

Issue Dep. DATA Center.

Do not copy without permission

Series No. **60**

FTT005 Thick Film Chip Resistors Product Specification

Document No.	IE-SP-157
Released Date	2019/03/06
Page No.	3

5 Structure Graph:

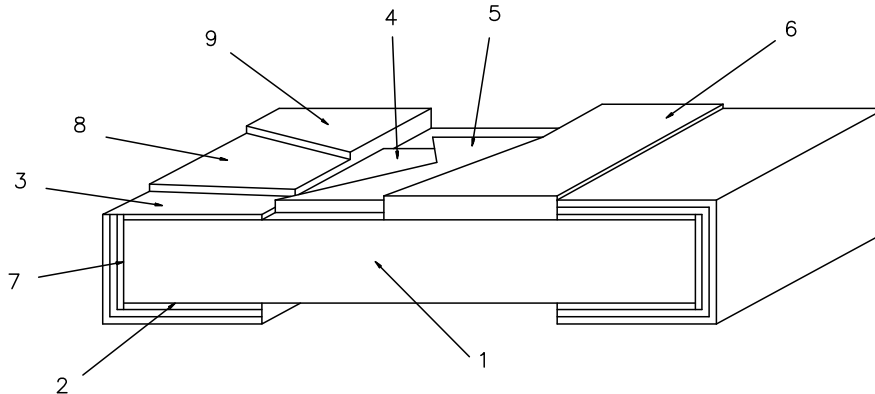

1	Ceramic substrate	6	2nd Protective coating
2	Bottom inner electrode	7	Terminal inner electrode
3	Top inner electrode	8	Ni plating
4	Resistive layer	9	Sn plating
5	1st Protective coating		

6 Reliability Test:

6.1 Electrical Performance Test

Item	Conditions	Specifications	
		Resistors	Jumper
Temperature Coefficient of Resistance	$TCR \text{ (ppm / } ^\circ\text{C)} = \frac{R2 - R1}{R1 (T2 - T1)} \times 10^6$ R1: Resistance at room temperature R2: Resistance at -55°C or +125°C T1: Room temperature T2: Temperature -55°C or +125°C Refer to JIS-C5201-1 4.8	Refer to item 3. general specifications	NA
Short Time Overload	Applied 2.5 times rated voltage for 5 seconds and release the load for about 30 minutes, then measure its resistance variance rate. (Rated voltage refer to item 3. general specifications) Jumper : Applied Maximum overload current 1.25A. Refer to JIS-C5201-1 4.13	$\Delta R\% = \pm 2.0\%$ No evidence of mechanical damage. No short or burned on the appearance.	Refer to item 3. general specifications
Dielectric Withstand Voltage	Put the resistor in the fixture, add 100VAC in +, - terminal for. 1 minute. Refer to JIS-C5201-1 4.7	No short or burned on the appearance.	
Intermittent Overload	Put the tested resistor in chamber under temperature 25±2°C and load 2.5 times rated DC voltage for 1 sec on, 25 sec off, 10000+400/-0 test cycles, then it be left at no-load for 1 hour, then measure its resistance variance rate. Jumper : Applied Maximum overload current:1.25A. Refer to JIS-C5201-1 4.13	$\Delta R\% = \pm 2.0\%$ No evidence of mechanical damage. No short or burned on the appearance.	Refer to item 3. general specifications

Remark

IT'S NOT UNDER CONTROL FOR PDF FILE
PLS NOTE THE VERSION STATED..

Issue Dep. DATA Center.

Do not copy without permission

Series No. **60**

FTT005 Thick Film Chip Resistors Product Specification

Document No.	IE-SP-157
Released Date	2019/03/06
Page No.	4

6.2 Mechanical Performance Test

Item	Conditions	Specifications	
		Resistors	Jumper
Solderability	<p>Preconditioning Put the tested resistor in the apparatus of PCT, at a temperature of 105°C, humidity of 100% RH, and pressure of 1.22×10⁵ Pa for a duration of 4 hours. Then after left the tested resistor in room temperature for 2 hours or more.</p> <p>Test method: The resistor be immersed into solder pot in temperature 235±5°C for 2 sec, then the resistor is left as placed under microscope to observed its solder area. Refer to JIS-C5201-1 4.17</p>	Solder coverage over 95%	
Resistance to Soldering Heat	<p>◎Test method 1 (Solder pot test): The tested resistor be immersed into molten solder of 260+5/-0°C for 10 seconds. Then the resistor is left in the room for 1 hour.</p> <p>◎Test method 2 (Solder pot test): The tested resistor be immersed into molten solder of 260+5/-0°C for 30 seconds. Then the resistor is left as placed under microscope to observe its solder area.</p> <p>◎Test method 3 (Electric iron test): Preheating temperature : 350±10°C Electric iron preheating time : 3+1/-0 sec Preheating the electric iron on electrode termination, as after that step placed the iron over 60 min. and measured its resistance variance rate.</p> <p>Refer to JIS-C5201-1 4.18</p>	<p>Test item 1: (1).Variance rate on resistance: $\Delta R\% = \pm 2.0\%$</p> <p>(2).No evidence of electrode damage. No side conductive peeling off.</p> <p>Test item 2: (1).Solder coverage over 95%. (2).The underlying material (such as ceramic) shall not be visible at the crest corner area of the electrode.</p> <p>Test item 3: (1).Variance rate on resistance: $\Delta R\% = \pm 2.0\%$</p> <p>(2).No evidence of electrode damage. No side conductive peeling off.</p>	Refer to item 3. general specifications

Remark

IT'S NOT UNDER CONTROL FOR PDF FILE
PLS NOTE THE VERSION STATED..

Issue Dep.**DATA Center.**

Do not copy without permission

Series No. **60**

FTT005 Thick Film Chip Resistors Product Specification

Document No.

IE-SP-157

Released Date

2019/03/06

Page No.

5

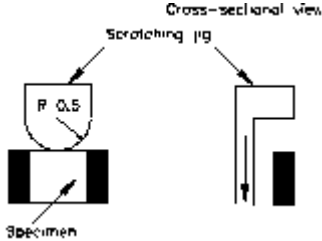
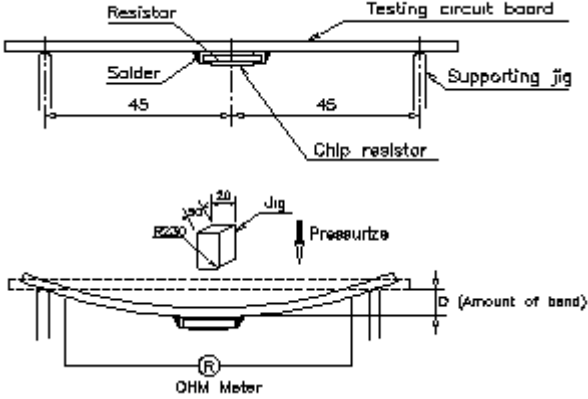
Item	Conditions	Specifications	
		Resistors	Jumper
Joint Strength of Solder	<p>Preconditioning Put tested resistor in the apparatus of PCT, at a temperature of 105°C, humidity of 100% RH, and pressure of 1.22x10⁵ Pa for a duration of 4 hours. Then after left the specimen in a temperature for 2 hours or more.</p> <p>◎Test item 1 (Adhesion): A static load using a R0.1 scratch tool shall be applied on the core of the component and in the direction of the arrow and held for 10 seconds and under load measured its resistance variance rate. Load:5N</p> 	<p>Test item 1: (1).Variance rate on resistance $\Delta R\%=\pm 1.0\%$</p> <p>(2).No evidence of mechanical damage. No terminal peeling off.</p> <p>Test item 2: (1).Variance rate on resistance: $\Delta R\%=\pm 1.0\%$</p> <p>(2).No evidence of mechanical damage. No terminal peeling off and core body cracked.</p>	<p>Refer to item 3. general specifications</p>
	<p>Refer to JIS-C5201-1 4.32</p> <p>◎Test item 2 (Bending Strength): Solder tested resistor on to PC board add force in the middle down, and under load measured its resistance variance rate. D:3mm</p>  <p>Refer to JIS-C5201-1 4.33</p>		

Remark

IT'S NOT UNDER CONTROL FOR PDF FILE
PLS NOTE THE VERSION STATED..

Issue Dep. DATA Center.

Do not copy without permission

Series No. **60**

FTT005 Thick Film Chip Resistors Product Specification

Document No.	IE-SP-157
Released Date	2019/03/06
Page No.	6

6.3 Environmental Test

Item	Conditions	Specifications									
		Resistors	Jumper								
Resistance to Dry Heat	Put tested resistor in chamber under temperature 125±3°C for 1000 +48/-0 hours. Then leaving the tested resistor in room temperature for 60 minutes, and measure its resistance variance rate. Refer to JIS-C5201-1 4.25	ΔR%=±2.0%	Refer to item 3. general specifications								
		No evidence of mechanical damage. No short or burned on the appearance.									
Thermal Shock	Put the tested resistor in the chamber under the Thermal Shock which shown in the following table shall be repeated 300 times consecutively. Then leaving the tested resistor in the room temperature for 1 hours, and measure its resistance variance rate. <table border="1" style="margin: 10px auto; border-collapse: collapse; text-align: center;"> <thead> <tr> <th colspan="2">Testing Condition</th> </tr> </thead> <tbody> <tr> <td>Lowest Temperature</td> <td>-55±5°C</td> </tr> <tr> <td>Highest Temperature</td> <td>125±5°C</td> </tr> <tr> <td>Temperature-retaining time</td> <td>15 minutes each</td> </tr> </tbody> </table> Refer to MIL-STD 202 Method 107	Testing Condition		Lowest Temperature	-55±5°C	Highest Temperature	125±5°C	Temperature-retaining time	15 minutes each	ΔR%=±2.0%	Refer to item 3. general specifications
		Testing Condition									
Lowest Temperature	-55±5°C										
Highest Temperature	125±5°C										
Temperature-retaining time	15 minutes each										
		No evidence of mechanical damage. No short or burned on the appearance.									
Loading Life in Moisture	Put the tested resistor in the chamber under temperature 40±2°C, relative humidity 90~95% and load the rated voltage for 90 minutes on, 30 minutes off, total 1000 hours. Then leaving the tested resistor in room temperature for 60 minutes, and measure its resistance variance rate. Refer to JIS-C5201-1 4.24	ΔR%=±5.0%	Refer to item 3. general specifications								
		No evidence of mechanical damage. No short or burned on the appearance.									
Load Life	Put the tested resistor in chamber under temperature 70±2°C and load the rated voltage for 90 minutes on, 30 minutes off, total 1000 hours. Then leaving the tested resistor in room temperature for 60 minutes, and measure its resistance variance rate. Refer to JIS-C5201-1 4.25	ΔR%=±5.0%	Refer to item 3. general specifications								
		No evidence of mechanical damage. No short or burned on the appearance.									
Low Temperature Operation	Put the tested resistor in the chamber at room temperature 25°C. Decreasing the temperature to -55°C and keep the temperature at -55°C for 1 hour. Then load the rated voltage for 45 minutes on, and 15 minutes off. Then leaving the tested resistor in room temperature for 8±1 hours, and measure its resistance variance rate. Refer to MIL-R-55342D 4.7.4	ΔR%=±2.0%	Refer to item 3. general specifications								
		No evidence of mechanical damage. No short or burned on the appearance.									

7 Plating Thickness:

7.1 Ni: ≥ 1 μm

7.2 Sn(Tin): ≥ 3 μm

7.3 Sn(Tin): Matte Sn

Remark	IT'S NOT UNDER CONTROL FOR PDF FILE PLS NOTE THE VERSION STATED..	Issue Dep. DATA Center.
	Do not copy without permission	Series No. 60

FTT005 Thick Film Chip Resistors Product Specification

Document No.	IE-SP-157
Released Date	2019/03/06
Page No.	7

8 Technical application notes (This is for recommendation, please customer perform adjustment according to actual application):

8.1 Recommend Soldering Method:

8.1.1 Lead Free IR Reflow Soldering Profile

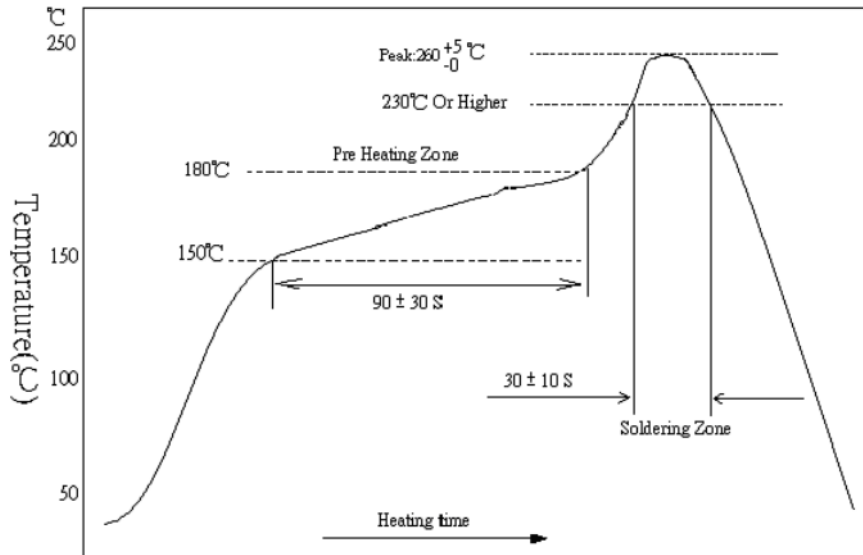

Remark: The peak temperature of soldering heat is 260 +5/-0 °C for 10 seconds

8.1.2 Soldering Iron: temperature 350°C ± 10°C, dwell time shall be less than 3 sec.

8.2 Recommend Land Pattern Design (For Reflow Soldering)

When a component is soldered, the resistance after soldering changes slightly depending on the size of the soldering area and the amount of soldering. When designing a circuit, it is necessary to consider the effect of a decrease or increase in its resistance

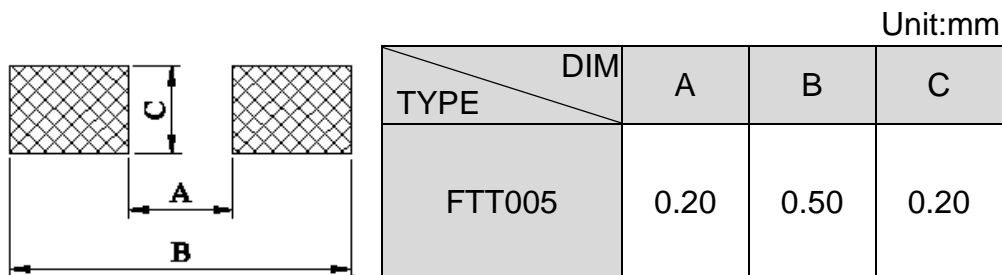

Remark

IT'S NOT UNDER CONTROL FOR PDF FILE
PLS NOTE THE VERSION STATED..

Issue Dep. DATA Center.

Do not copy without permission

Series No. **60**

FTT005 Thick Film Chip Resistors Product Specification

Document No.	IE-SP-157
Released Date	2019/03/06
Page No.	8

8.3 Environment Precautions:

This specification product is for general electronic use, ABCO will not be responsible for any damage, cost or loss caused by using this specification product in any special environment. If other applications need to confirm with ABCO. If consumer intends to use our Company product in special environment or condition (including but not limited to those mentioned below), then will need to make individual recognition of product features and reliability accordingly.

- (a) Used in high temperature and humidity environment;
- (b) Exposed to sea breeze or other corrosive gas, such as Cl₂、H₂S、NH₃、SO₂ and NO₂;
- (c) Used in non-verified liquids including water, oil, chemical and organic solvents;
- (d) Using non-verified resin or other coating material to seal or coat our Company product;
- (e) After soldering, it is necessary to use water-soluble detergents to clean residual solder fluxes, even though no-clean fluxes are recommended.

8.4 Momentary Overload Precautions:

The product might be out of function when momentary overloaded. Please make sure to avoid momentary overloading while using and preserving.

8.5 Operation and Processing Precautions:

- (a) Avoid damage to the edge of resistor and protective layer caused by mechanical stress.
- (b) Handle with care when printing circuit board (PCB) is divided or fixed on support body, because bending of printing circuit board (PCB) mounting will make mechanical stress for resistors.
- (c) Make sure the power rating is under the limit when using the resistor. When power rating is over the limit, the resistor will be overloaded. There might be machinery damage due to the climbing temperature.
- (d) If the resistor will be exposed under massive impact load (shock wave) in a short period of time, the working environment must be set up well before use.
- (e) Please make evaluation and confirmation when the product is well used in your company and have a through consideration of it's fail-safe design to ensure the system safety.

Remark	<div style="border: 1px solid black; padding: 5px; display: inline-block;"> IT'S NOT UNDER CONTROL FOR PDF FILE PLS NOTE THE VERSION STATED.. </div>	Issue Dep. DATA Center.
	Do not copy without permission	Series No. 60



FTT005 Thick Film Chip Resistors Product Specification

Document No.	IE-SP-157
Released Date	2019/03/06
Page No.	9

9 Stock period:

- 9.1 The temperature condition must be controlled at $25\pm 5^{\circ}\text{C}$, the R.H. must be controlled at $60\pm 15\%$. The stock can maintain quality level in two years.
- 9.2 Please avoid the mentioned harsh environment below when storing to ensure product performance and its' weldability. Places exposed to sea breeze or other corrosive gas, such as Cl_2 、 H_2S 、 NH_3 、 SO_2 and NO_2 .
- 9.3 When the product is moved and stored, please ensure the correct orientation of the box. Do not drop or squeeze the box. Otherwise, the electrode or the body of the product may be damaged.

10 The carton packaged for electronic-information products is made by the symbol as follows: (for China)

	
Marking for control of pollution cause by electronic-information products	Marking for package recovery

11 Attachments:

- 11.1 Document Revise Record (QA-QR-027)

Remark	IT'S NOT UNDER CONTROL FOR PDF FILE PLS NOTE THE VERSION STATED..	Issue Dep. DATA Center.
	Do not copy without permission	Series No. 60

FTT005 Thick Film Chip Resistors Product Specification

Document No.	IE-SP-157
Released Date	2019/03/06
Page No.	10

Legal disclaimer

ABCO, its distributors and agents (collectively, "ABCO"), hereby disclaims any and all liabilities for any errors, inaccuracies or incompleteness contained in any product related information, including but not limited to product specifications, datasheets, pictures and/or graphics. ABCO may make changes, modifications and/or improvements to product related information at any time and without notice.

ABCO makes no representation, warranty, and/or guarantee about the fitness of its products for any particular purpose or the continuing production of any of its products. To the maximum extent permitted by law, RALEC disclaims (i) any and all liability arising out of the application or use of any ABCO product, (ii) any and all liability, including without limitation special, consequential or incidental damages, and (iii) any and all implied warranties, including warranties of fitness for a particular purpose, non-infringement and merchantability.

ABCO defined this product is for general electrical use, not design for any application for automotive electrical ,life-saving or life support equipment, or any application which may inflict casualties if ABCO product failure occurred. When consumer is using or selling products of ABCO without having discussion with the sales representatives and specifically stated the applicability mentioned above in a written form, then the client need to take a full responsibility and agree to protect ABCO from punishment and damage.

Information provided here is intended to indicate product specifications only. ABCO reserves all the rights for revising this content without further notification, as long as products are unchanged. Any product change will be announced by ECN.

Remark	IT'S NOT UNDER CONTROL FOR PDF FILE PLS NOTE THE VERSION STATED..	Issue Dep. DATA Center.
	Do not copy without permission	Series No. 60